

INSTALLATION GUIDE

Door Jamb Bubble Seal

The following installation instructions are given as a general guide to avoid common errors. Installer should follow best practices for construction and workmanship. Acoustical Solutions bears no responsibility for installation or contractor selection. Please contact a sales representative if you have questions, concerns or specific project requirements.

Be sure to inspect materials upon delivery. Please note any damage on the delivery ticket and notify Acoustical Solutions immediately. Materials should be stored in original packing in a clean, climate controlled environment free of moisture. Installation should not commence until building is enclosed and under standard occupancy conditions and surfaces are of acceptable condition and properly prepared. Do not install materials of unacceptable quality.

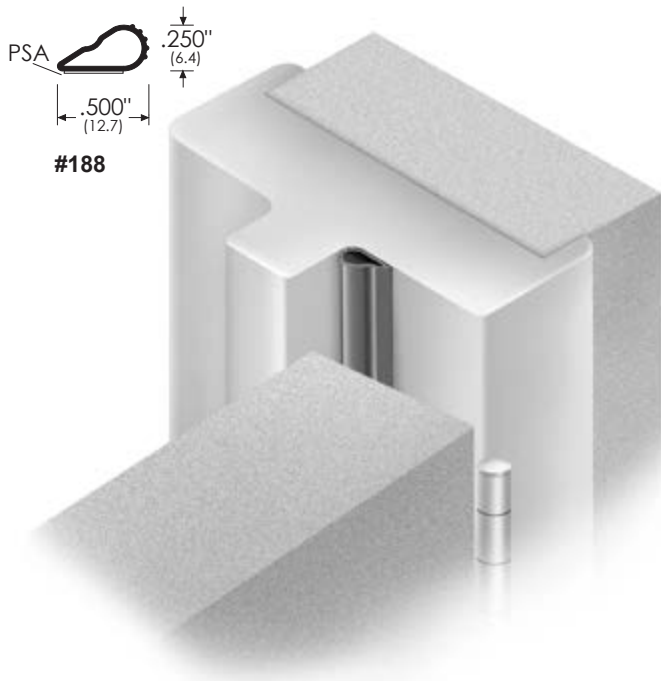

Before Installation:

- 1** For proper adhesion, clean surface of frame where the gasketing is to be applied (See illustration). Check for any impediments (dust, dirt, oil, grease, etc.) or loose paint and remove them from the surface area. Solvent cleaner or common detergent cleaner may be used.
- 2** Surface area must be completely dry before the installation process begins.
- 3** Gasketing is best applied at a temperature range of 70° to 90°F (21 to 32°C). Do not apply if temperature falls below 50°F (10°C) or exceeds 100°F (38°C).
- 4** Gasketing should be installed after the doors and frames have been finish painted and the paint has dried.

To Install:

- 1** Measure and cut the gasket to fit the head and jambs. The first piece of gasketing should be the head piece and applied on the entire length of the head (See illustration below for location on head). Remove the paper backing of self adhesive strip (PSA) about 1' to 2' (304.8 to 609.6mm) at a time. Align and install gasketing into place. Press firmly for proper adhesion.

IMPORTANT: DO NOT STRETCH THE SEAL DURING INSTALLATION.

- 2** The lock jamb gasketing should be installed next (Location as illustrated), following procedures as outlined in step 1.
- 3** Install the hinge jamb gasketing last (Location as illustrated), following procedures as outlined in step 1.
- 4** After installation, check to make sure the gasketing does not obstruct the operation of door.

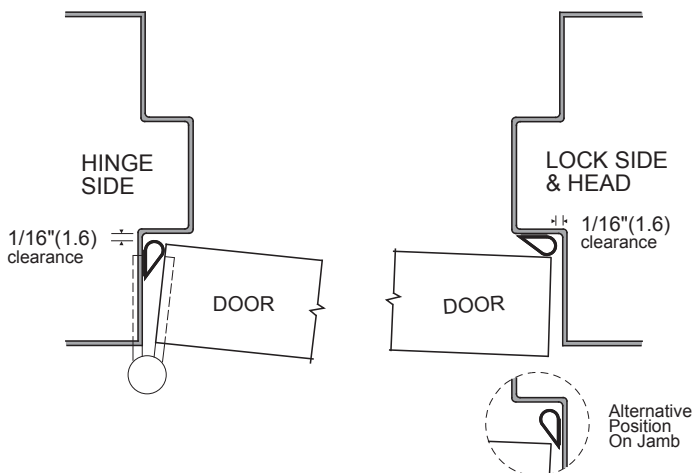

Revised: 2025-04-30