

# Hanging Sound Baffles

**Please Note:** These installation instructions are given as a general guide to avoid common errors. Installer should follow best practices for construction and workmanship. Acoustical Solutions bears no responsibility for installation or contractor selection. Please contact a sales representative if you have questions, concerns or specific project requirements.

Be sure to inspect materials upon delivery. Please note any damage on the delivery ticket and notify Acoustical Solutions immediately. Materials should be stored in original packing in a clean, climate controlled environment free of moisture. Installation should not commence until building is enclosed and under standard occupancy conditions and surfaces are of clean, acceptable condition and properly prepared. Installation is best done at the end of a construction project. Do not install materials of unacceptable quality.

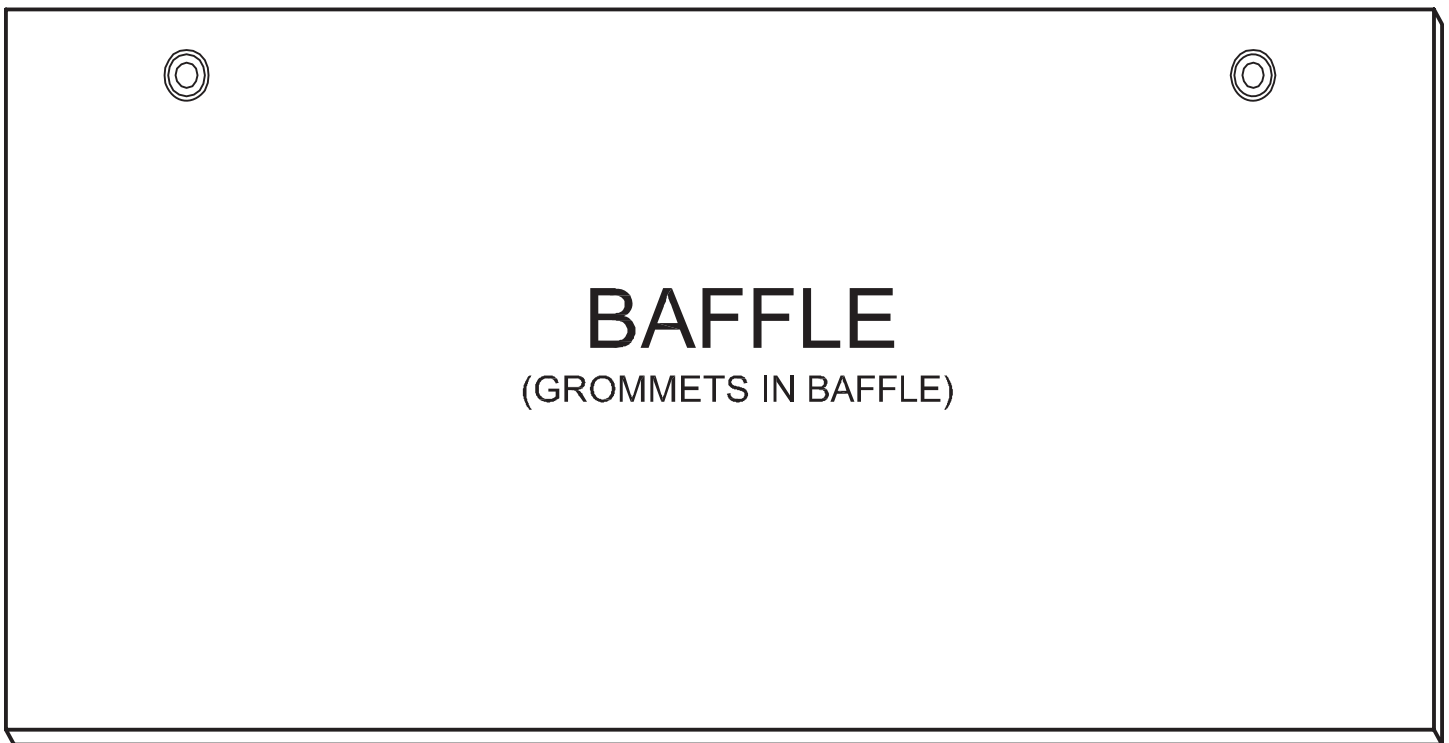

Revised: 2025-04-30

# Hanging Sound Baffles

## Suggested Patterns

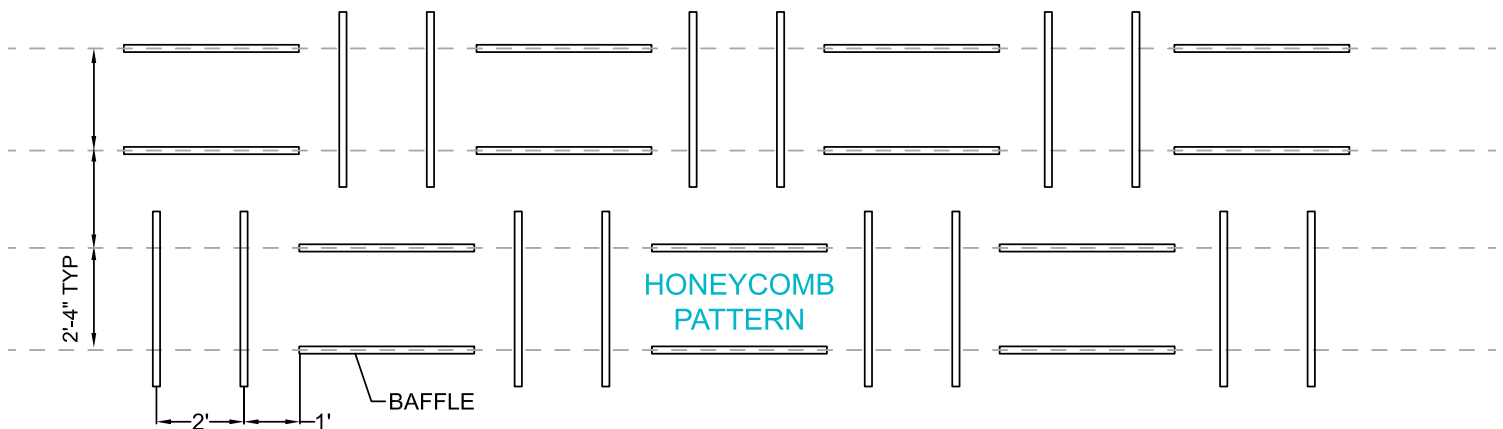
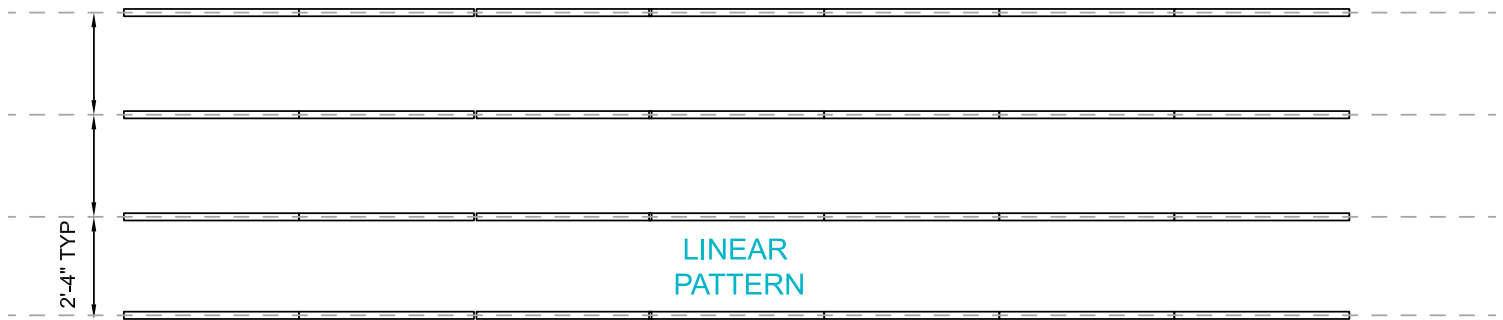
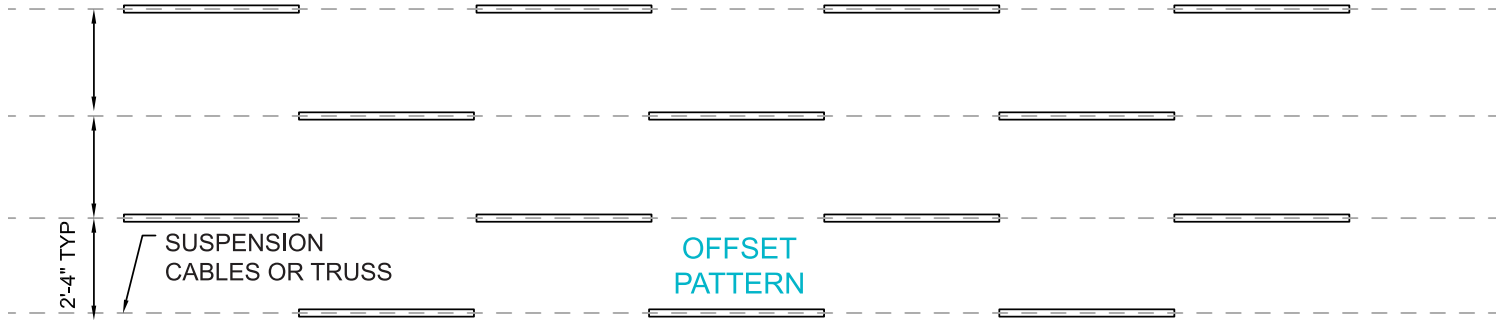

Revised: 2025-04-30

# Hanging Sound Baffles

## Direct to Roof Deck

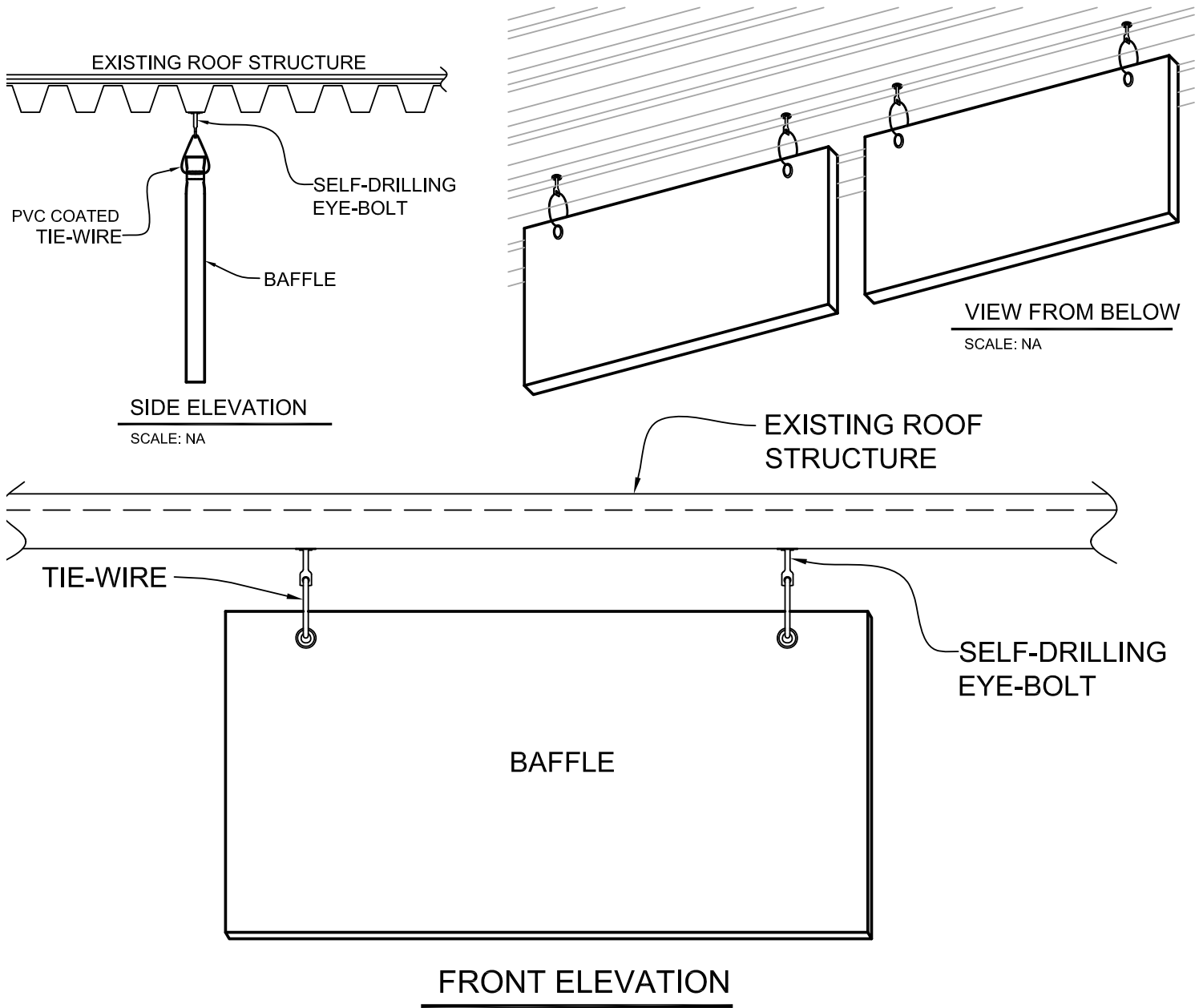

**NOTES:**

- 1. Do not over tighten or put excessive force on grommets as this may cause baffle failure
- 2. Tie-wire is recommended to connect directly above grommet. Avoid attaching at odd angles, as this causes undue stress on grommets.
- 3. Preferred method of suspension.
- 4. Tie-wire to be snugged tight to cable so to prevent slippage.

Revised: 2025-04-30

# Hanging Sound Baffles

## Attachment to Bottom Chord

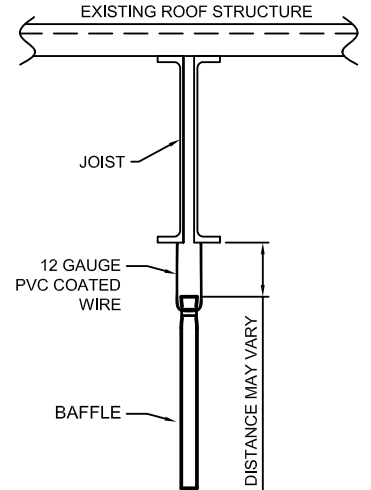
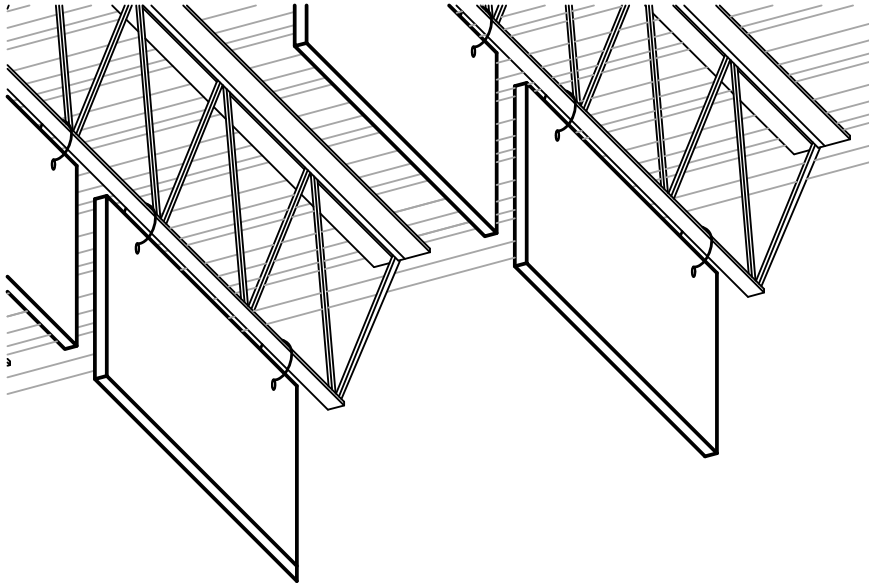

**SIDE ELEVATION**

SCALE: NA

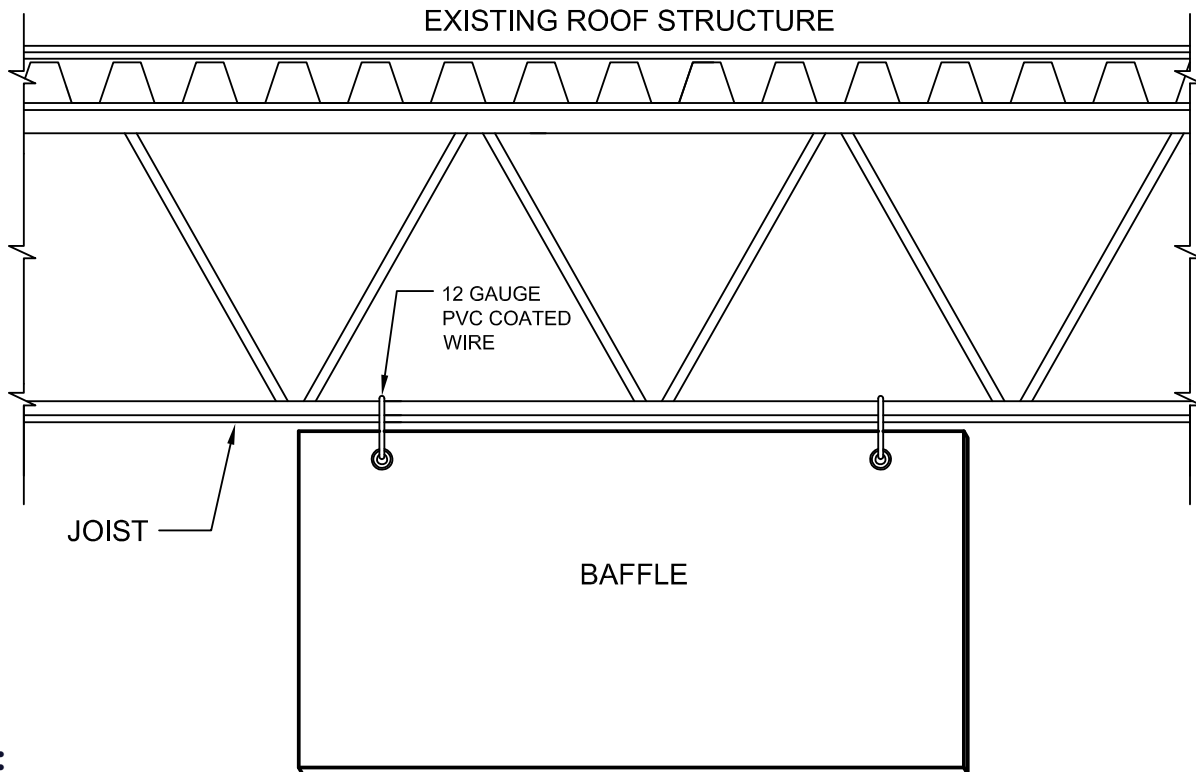

### NOTES:

1. Tie-wires are anchored to bottom chord of joist.
2. Tie-wire to be snugged up tight to prevent slippage.

Revised: 2025-04-30

# Hanging Sound Baffles

## Attachment to Top Chord

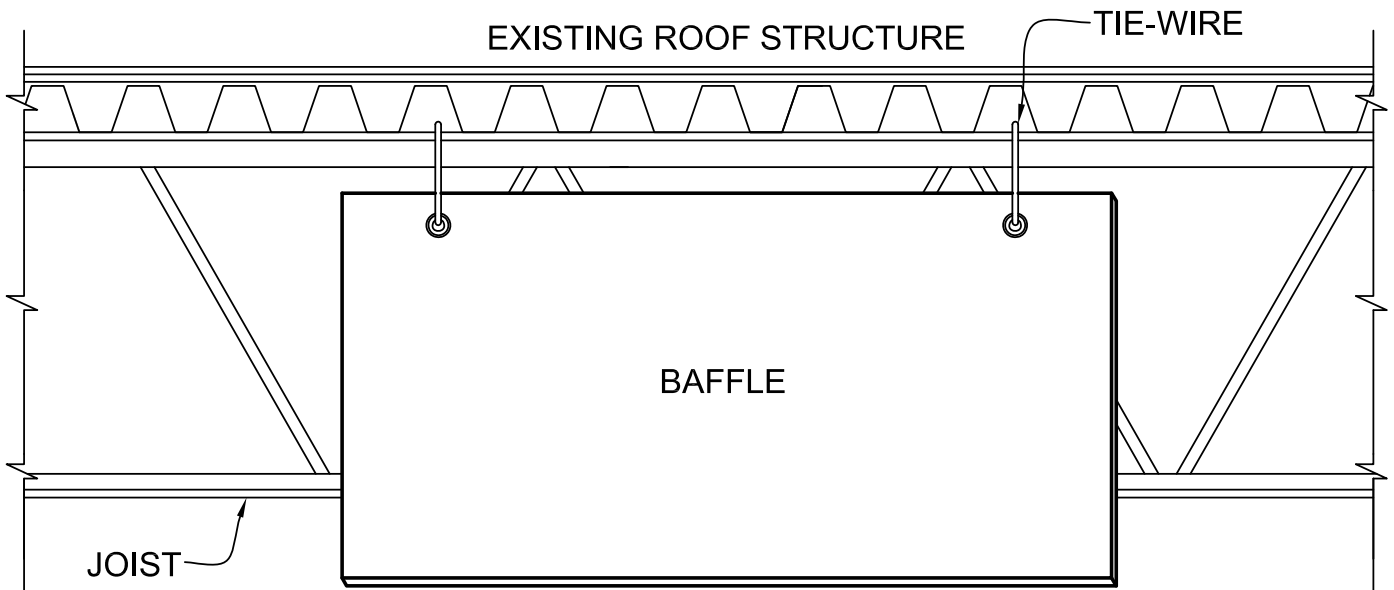
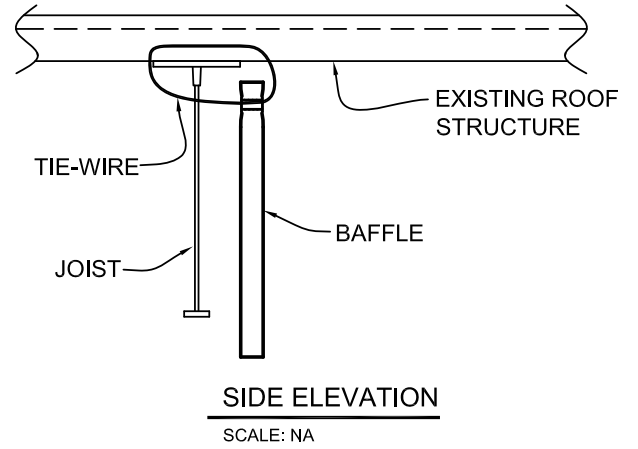
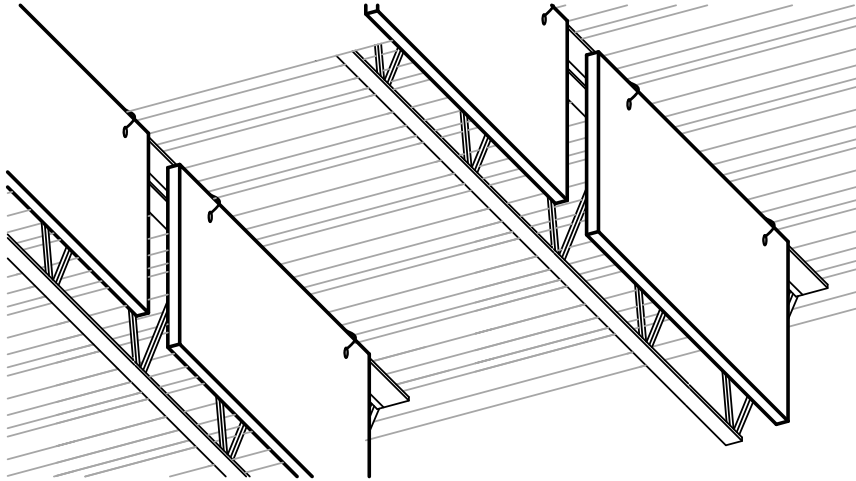

### NOTES:

1. Tie-wires are anchored to top chord of joist.
2. Tie-wire to be snugged up tight to prevent slippage.

Revised: 2025-04-30

# Hanging Sound Baffles

## Attachment with Grid Clip

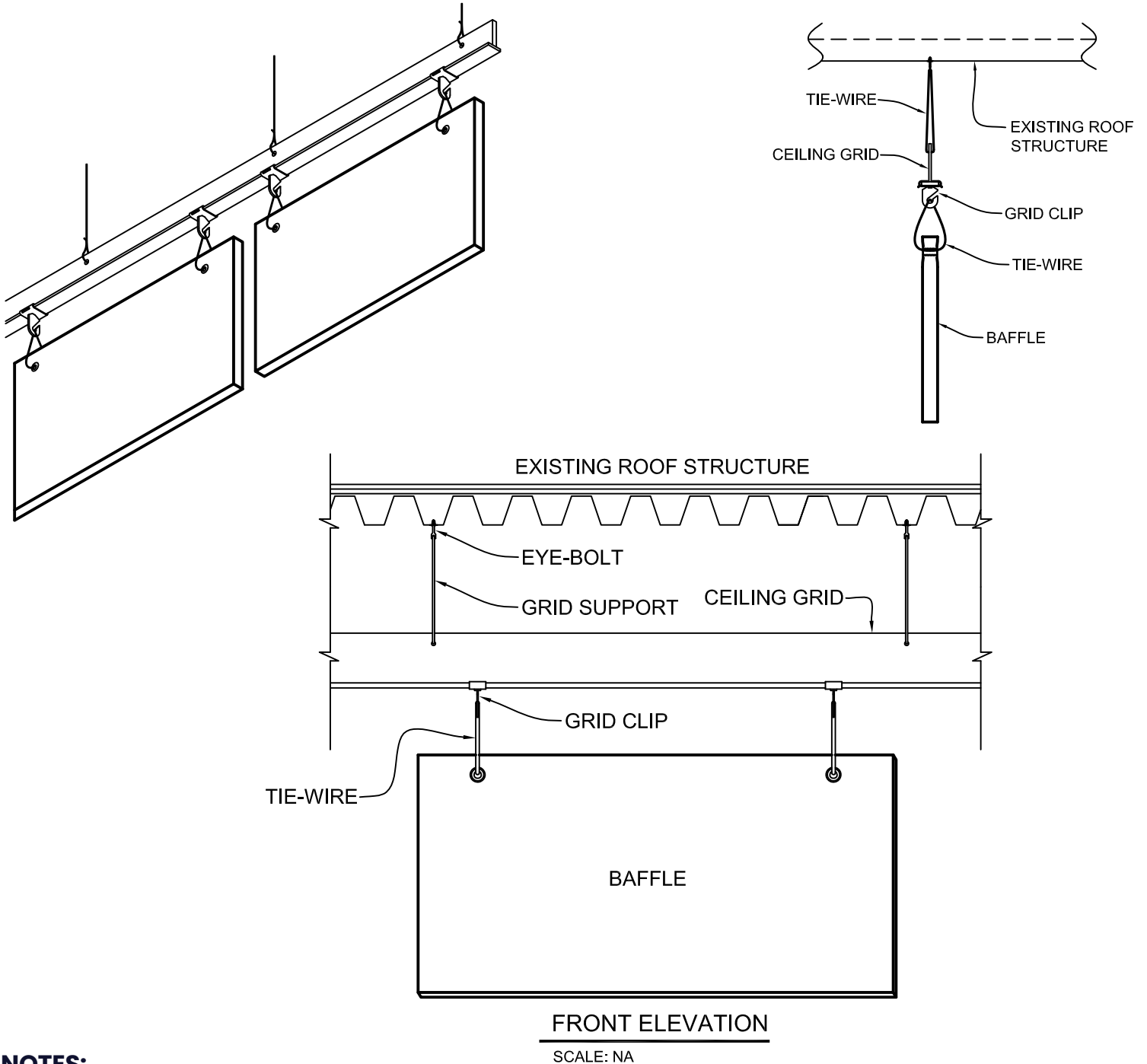

### NOTES:

1. Using fixed or swivel grid clips, baffles can be attached to ceiling grid.
2. Tie-wire to be snugged to up tight to prevent slippage

Revised: 2025-04-30

# Hanging Sound Baffles

## Cable Installation

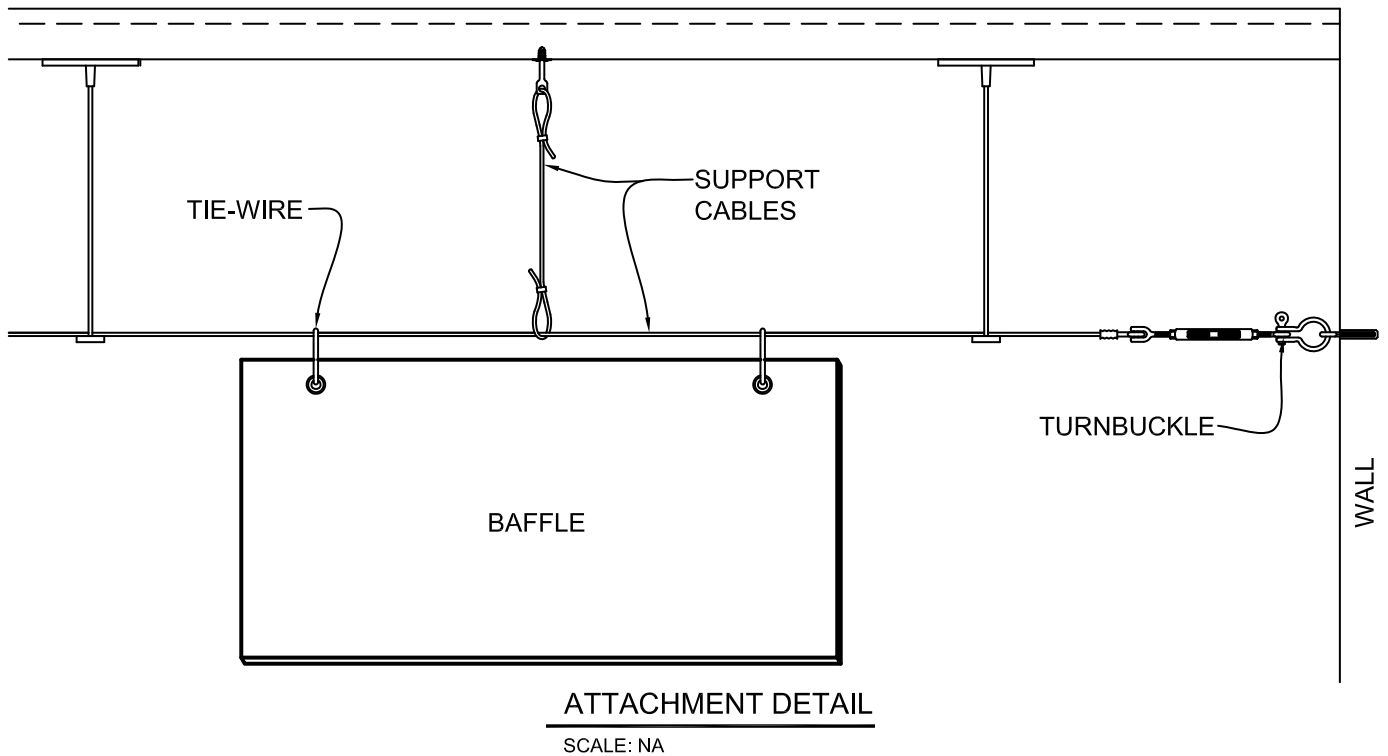
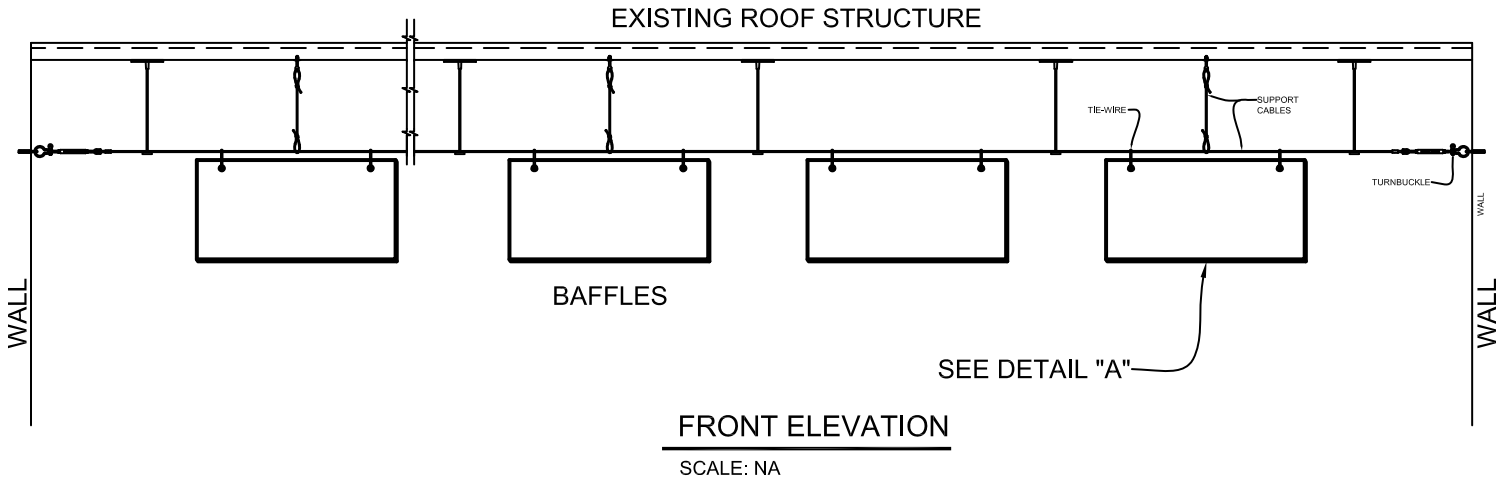

### NOTES:

1. Secure anchors at both ends into wall. Tighten Cable using turnbuckles. On extremely long runs of cable, intermediate vertical cable support may be required.
2. Tie-wire to be snugged up tight to cable to prevent slippage.

Revised: 2025-04-30

# Hanging Sound Baffles

## Cable Top Chord

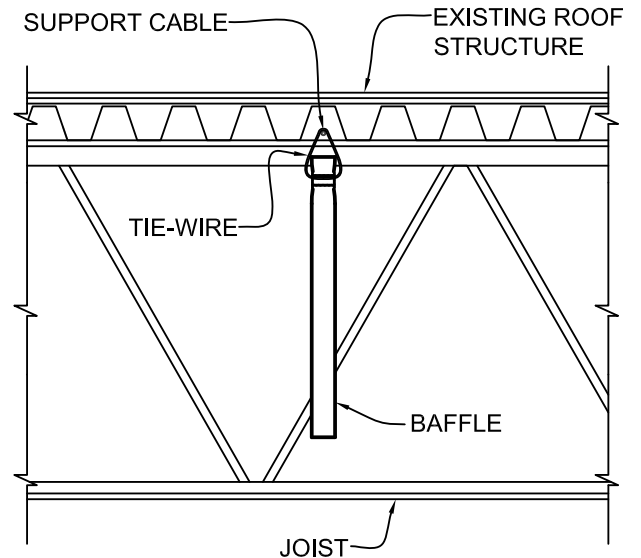
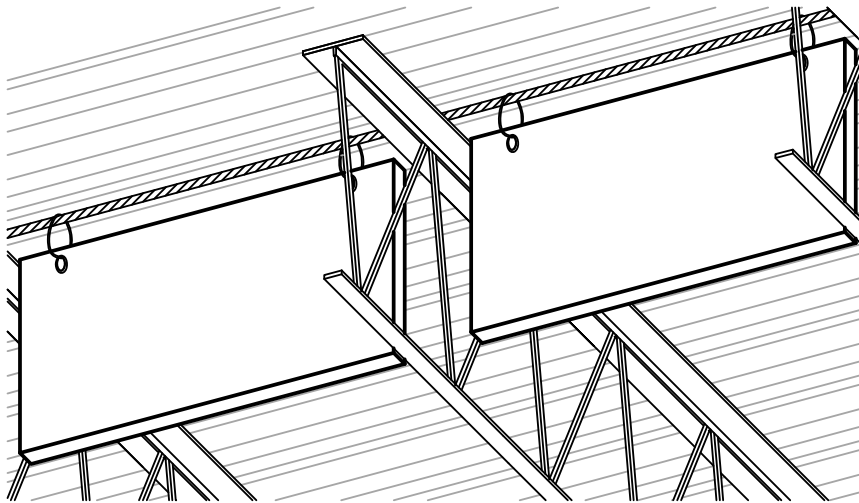

**SIDE ELEVATION**  
SCALE: NA

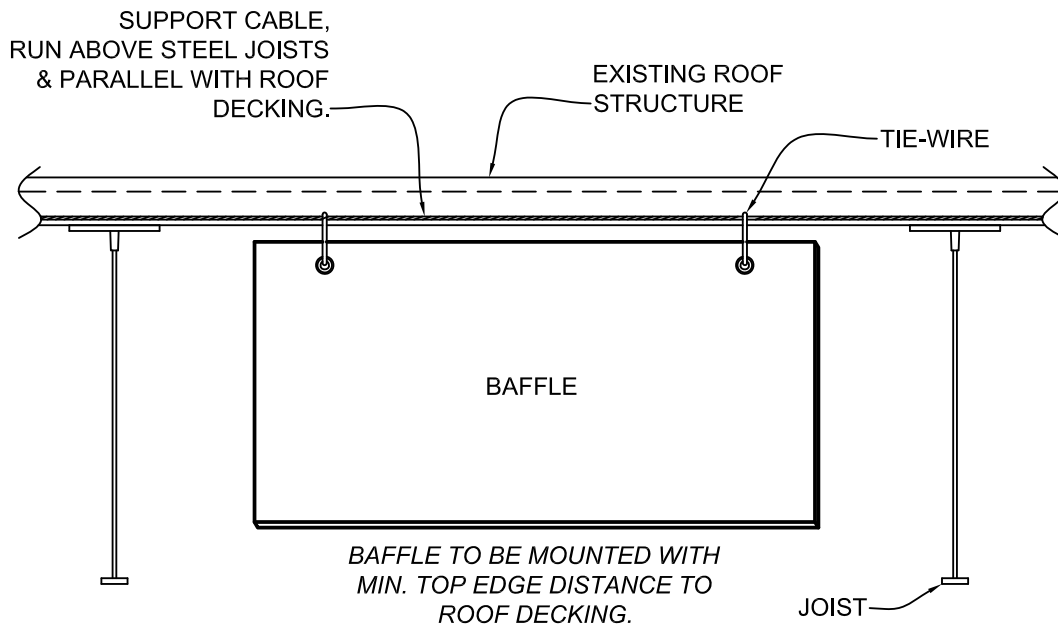

**FRONT ELEVATION**  
SCALE: NA

### NOTES:

1. Cables are stretch perpendicular to bar joists and parallel to deck flutes. Cable can be installed high over top of bar joist which will provide a natural intermittent support for the cable.
2. Tie-wire to be snugged up tight to cable to prevent slippage.

Revised: 2025-04-30

# Hanging Sound Baffles

## Cable Bottom Chord

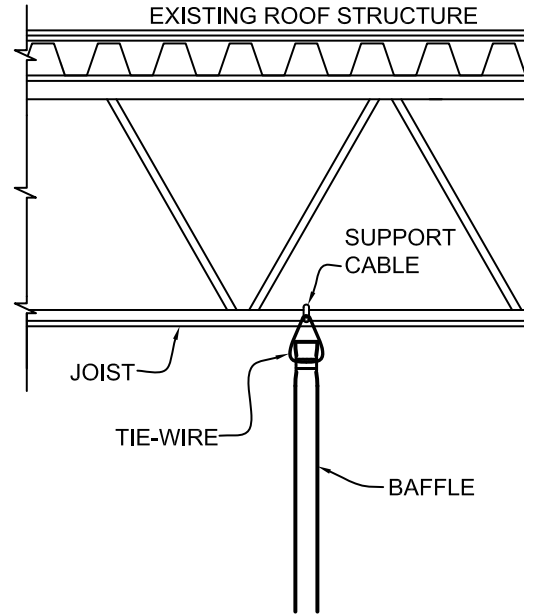
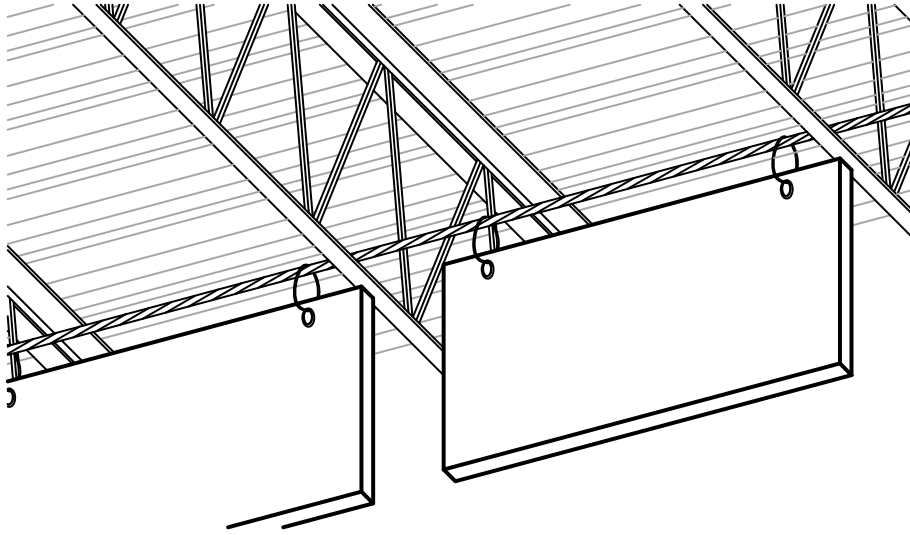

SIDE ELEVATION

SCALE: NA

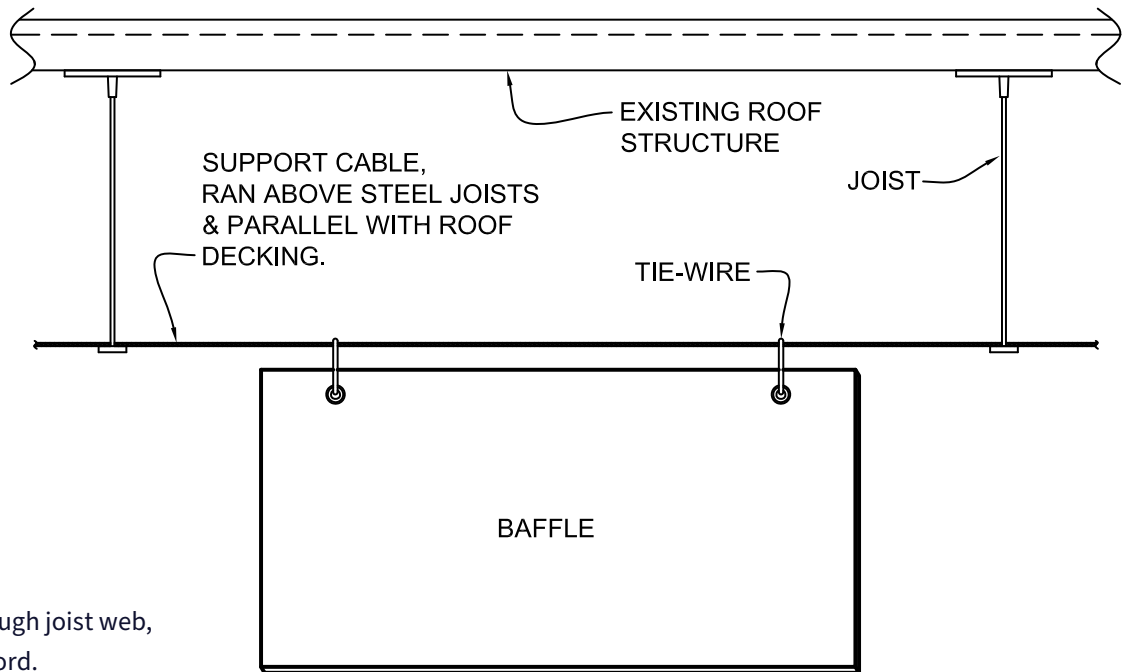

FRONT ELEVATION

SCALE: NA

### NOTES:

1. Cable is stretch through joist web, resting on bottom cord.
2. Tie-wire to be snugged up tight to cable to prevent slippage.

Revised: 2025-04-30

# Hanging Sound Baffles

## Wall Attachment Washers

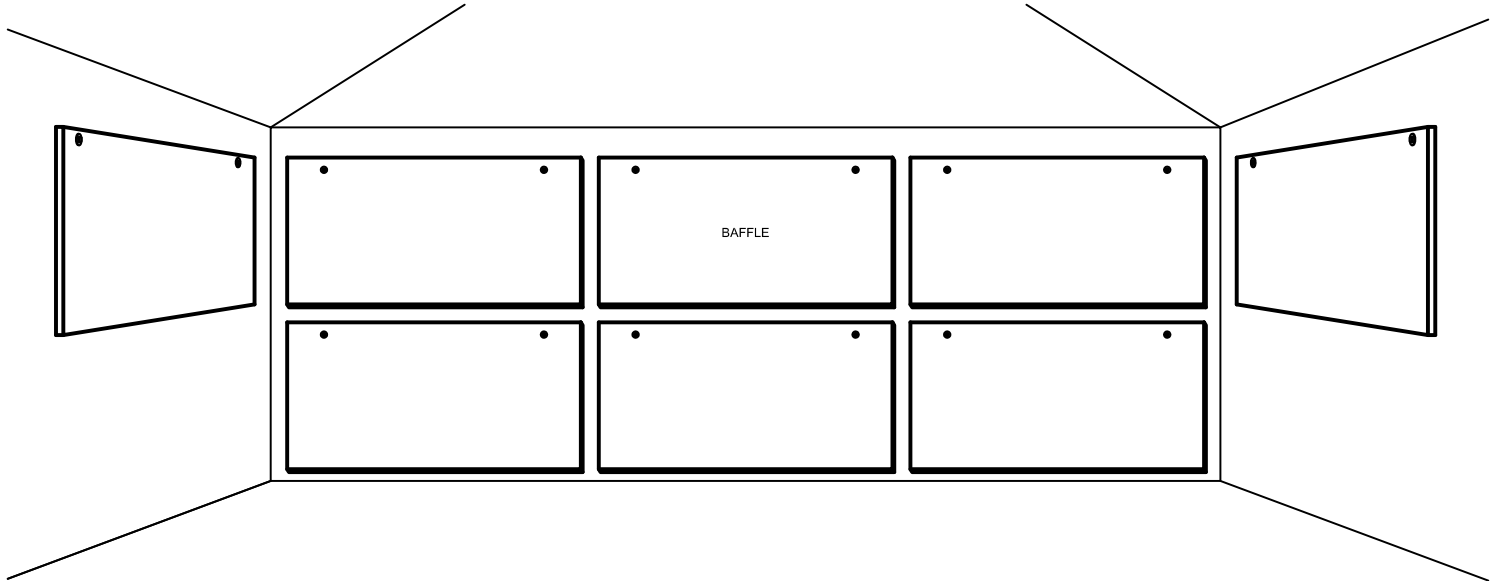

FRONT ELEVATION

SCALE: NA

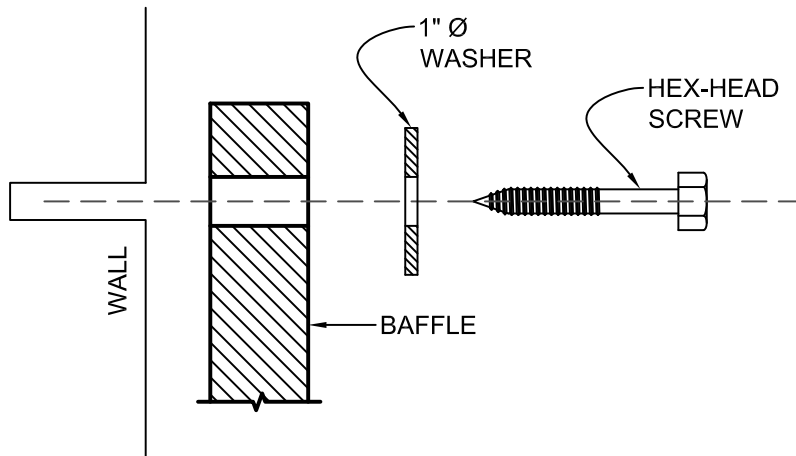

ATTACHMENT DETAIL

SCALE: NA

**NOTE:**

1. Do not over tighten hardware. Doing so can cause bottom of panel to kick out from the wall.

Revised: 2025-04-30

# Hanging Sound Baffles

## Wall Attachment Eyebolt

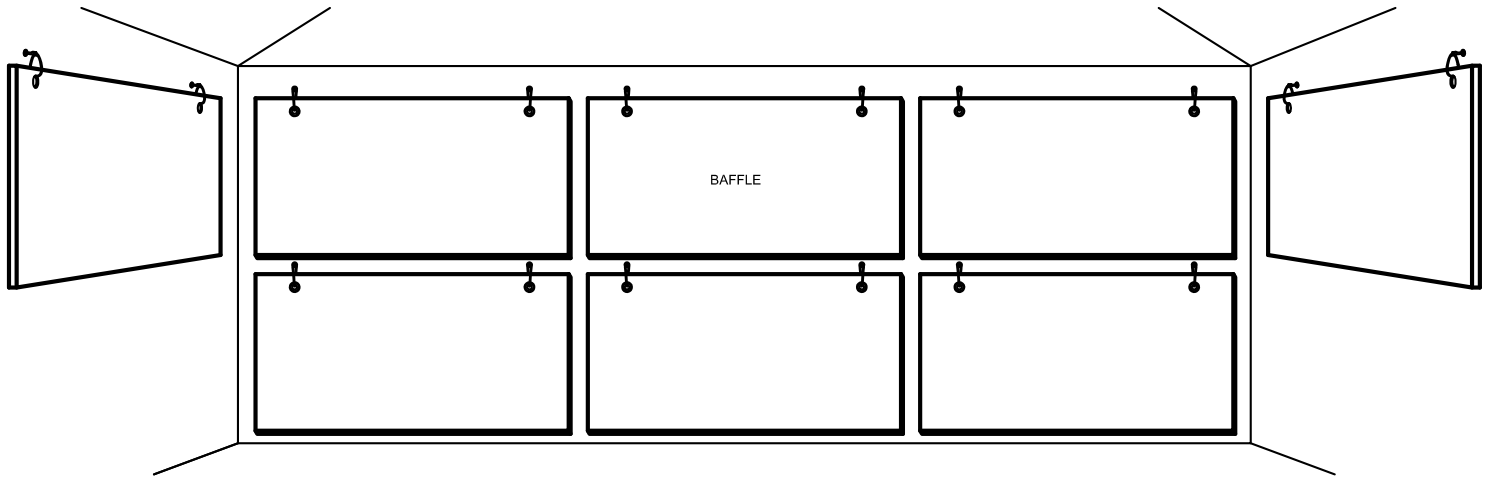

FRONT ELEVATION

SCALE: NA

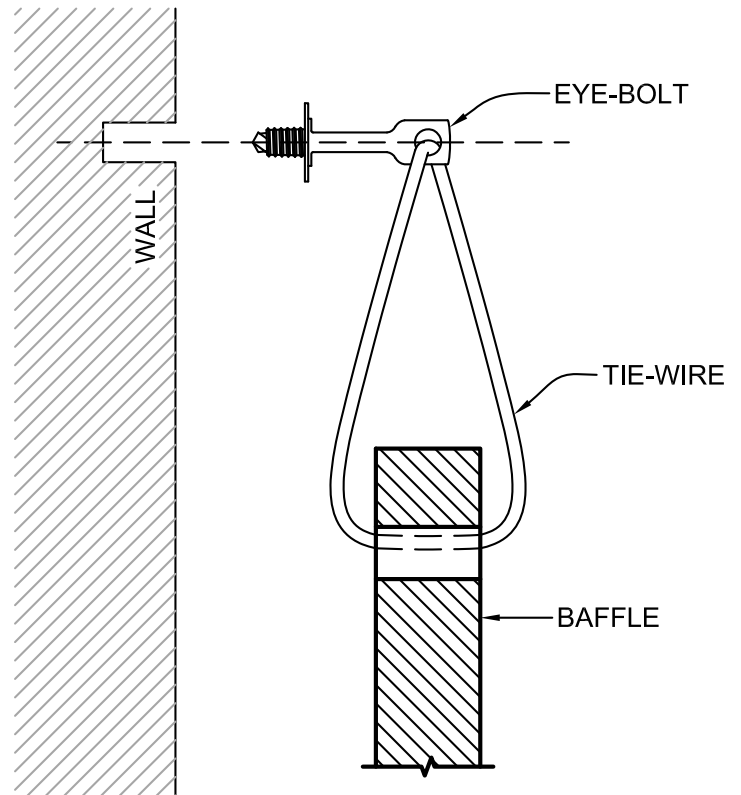

ATTACHMENT DETAIL

SCALE: NA

### NOTES:

1. Baffle attached to eyebolts with air space for increase acoustical absorption. Attachment is made with tie wraps, tie wires or appropriate fasteners.
2. Tie wire to be snugged up to cable to prevent slippage.

Revised: 2025-04-30