

INSTALLATION GUIDE

Iso-Step® Soundproofing Underlayment

The following installation instructions are given as a general guide to avoid common errors. Installer should follow best practices for construction and workmanship. Acoustical Solutions bears no responsibility for installation or contractor selection. Please contact a sales representative if you have questions, concerns or specific project requirements.

Be sure to inspect materials upon delivery. Please note any damage on the delivery ticket and notify Acoustical Solutions immediately. Materials should be stored in original packing in a clean, climate controlled environment free of moisture. Installation should not commence until building is enclosed and under standard occupancy conditions and surfaces are of acceptable condition and properly prepared. Do not install materials of unacceptable quality.

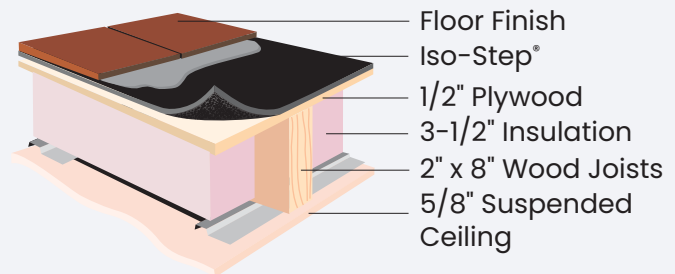
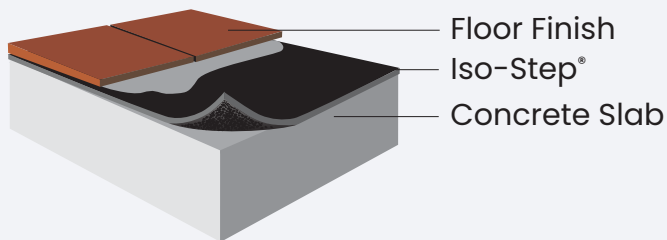

Revised: 2025-04-30

Iso-Step® Soundproofing Underlayment

Step 1

After installing a perimeter isolation strip, apply approved adhesive to the sub-floor using recommended trowel size.

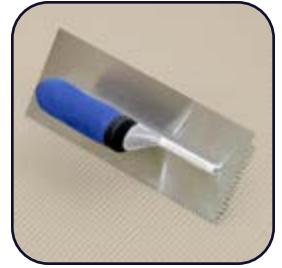

Step 2

Roll out and lay the Iso-Step® into the adhesive bond.



Step 3

Roll the Iso-Step® with an approved flooring roller.



Step 4

Apply adhesive to the Iso-Step® using recommended trowel size.



Step 5

Lay finish floor layer according to flooring manufacturer's guidelines.

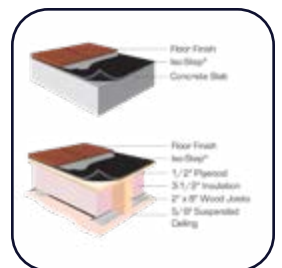

Revised: 2025-04-30

Iso-Step® Soundproofing Underlayment

General Information

The Iso-Step® line of products for impact sound insulation are engineered to provide the best performance of any sound control product available, and have been repeatedly tested to achieve proven results. It can be installed under most types of grouted, glued, and floating floors, including ceramic tile, stone, marble, brick, pavers, hardwood, engineered wood, laminate, parquet, LVT, and carpet. **Sheet vinyl is not approved for installation over Iso-Step®.** All floor covering assemblies shall have prior installation approval.

I. Job Site Conditions

Areas to receive Iso-Step® should be weather tight and maintained at a minimum, constant room temperature of 65°F (10°C) for 48 hours before, during, and after installation.

II. Subfloor Requirements & Preparation

A. GENERAL

NOTE: Please follow subfloor requirements and preparation recommendations as specified by the flooring manufacturer.

1. All subfloors/substrates must be inspected prior to installation.
2. Install Iso-Step® over concrete, gypsum, approved self-leveling materials, and wood.
3. Wood subfloors should be double construction, rigid, and free from movement.
4. Wood subfloors (when installed with grouted floor coverings like tile) must be prepared according to ANSI L/360 standards, or as required by the floor covering manufacturer.

NOTE: Particleboard, “chipboard,” masonite, and lauan are not suitable underlayments.

5. Concrete floors must be fully cured and permanently dry. Subfloor shall be dry, clean, smooth, level, and structurally sound. It should be free of dust, solvent, paint, wax, oil, grease, asphalt, sealers, curing and hardening compounds, alkaline salts, old adhesive residue, and other extraneous materials, according to ASTM F710.
6. Subfloor should be smooth to prevent irregularities, roughness, or other defects from telegraphing through the material. The surface should be flat to the equivalent of 3/16” (3.9mm) in 10 LF or as recommended by the flooring manufacturer.
7. Mechanically remove all traces of old adhesives, paint, or other debris by scraping, sanding, or scarifying the substrate. DO NOT use solvents.
8. Grind high spots until level and fill low spots with a patching /leveling compound.
9. All saw cuts (control joints), cracks, indentations, and other non-moving joints in the concrete must be filled with a Portland-based patching/leveling compound and dried thoroughly.
10. Any concrete subfloor can be a source of moisture-related flooring failures. It is the installer’s responsibility to test the concrete or other cement-like material for moisture.

continues...

Revised: 2025-04-30

Iso-Step® Soundproofing Underlayment

General Information

11. The maximum concrete moisture content or RH (Relative Humidity) must be measured using the ASTM F2170 standard test method.
 - A. Concrete substrates and any thickness of Iso-Step® Soundproofing Underlayment
 - i. Iso-Step® Soundproofing Underlayment Adhesive – RH limit of 99% – higher RH applications
 - ii. Iso-Step® Quick Cure Soundproofing Underlayment Adhesive – RH limit of 100% – highest RH applicationsIf levels are higher, then the installation must not proceed until the problem is corrected.

Note: The selected Portland-based patching and self-leveling materials must be moisture resistant and rated to withstand the RH moisture levels on the project.
12. In the event that a moisture mitigation system is required, it must conform to the ASTM F3010 Standard Practice for Two-Component Resin Based Membrane Forming Moisture Mitigation Systems for use Under Resilient Floor Coverings. In addition, the finished prepared surface on which the flooring is to be installed must conform to the ASTM F710 standards.
13. Perform pH tests on all concrete floors. If greater than the allowable limit of the selected Iso-Step® adhesive, neutralize prior to installation.
14. If using other approved adhesives, please refer to manufacturer's acceptable limits.

III. Hazards

- A. SILICA WARNING
 1. Concrete, floor patching compounds, toppings, and leveling compounds can contain free crystalline silica. Cutting, sawing, grinding, or drilling concrete can produce respirable crystalline silica (particles 1-10 micrometers). Respirable silica is classified by OSHA as an IA carcinogen and is known to cause silicosis and other respiratory diseases. Avoid actions that cause dust to become airborne. Use local or general ventilation or protective equipment to reduce exposure below applicable exposure limits.
- B. LEAD WARNING
 1. Certain paints may contain lead. Exposure to excessive amounts of lead dust presents a health hazard. Refer to applicable federal, state, and local laws and the publication, Lead Based Paint: Guidelines for Hazard Identification and Abatement in Public and Indian Housing, available from the United States Department of Housing and Urban Development.
- C. ASBESTOS WARNING
 1. Resilient flooring, backing, lining felt, paint, or asphaltic “cutback” adhesives could contain asbestos fibers. Avoid actions that cause dust to become airborne. DO NOT sand, dry sweep, dry scrape, drill, saw, beadblast, mechanically chip, or pulverize. Regulations may require that the material be tested to determine asbestos content. Consult the documents titled, Recommended Work Practices for Removal of Existing Resilient Floor Coverings, available from the Resilient Floor Covering Institute.

Revised: 2025-04-30

Iso-Step® Soundproofing Underlayment

General Information

IV. Material Storage and Handling

A. GENERAL

1. Deliver the material to the job site in its original unopened packaging with all labels intact and stored inside and appropriately to prevent damage.
2. Inspect all material for visual defects before beginning the installation.
3. Verify the material delivered is the correct type, thickness, and amount. Report any discrepancies immediately.

Acoustical Solutions will honor no labor claim on material installed with any visually apparent defects.

4. The material and any adhesive must be acclimated at room temperature for a minimum of 24 hours before starting the installation.
5. Roll material is stretched slightly when it is rolled at the factory. At the job site, the installer should allow all cuts to relax before gluing down. Shaking the material once it is unrolled can help it to relax more quickly.

V. Installation of Perimeter Isolation Strip

NOTE: The Perimeter Isolation Strip isolates the floor from the wall and breaks the vibration transmission path — it is essential to FIRST install the Perimeter Isolation Strip before placing and trimming Iso-Step® Underlayment!

1. Temporarily attach the Perimeter Isolation Strip to the perimeter wall of the entire subfloor, as well as around the perimeter of any protrusions, with tape, spray adhesive, etc.
2. Install the finished floor in accordance with the flooring manufacturer's directions. After installing the finished floor, trim the excess Perimeter Isolation Strip around the entire perimeter of the finished floor.

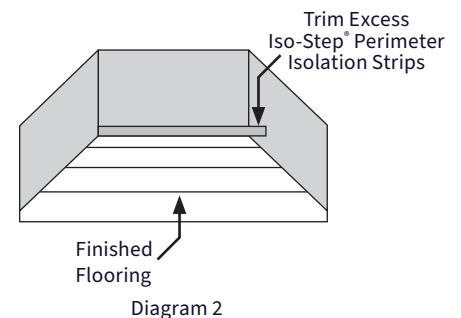
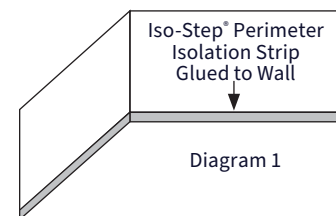

Iso-Step® Soundproofing Underlayment

General Information

VI. Installation of Iso-Step® Soundproofing Underlayment Rolls

NOTE: It is essential to FIRST install the Perimeter Isolation Strip before placing and trimming the Iso-Step® Soundproofing Underlayment material! The Perimeter Isolation isolates the floor from the wall and breaks the vibration transmission path.

A. Installing Iso-Step®

1. FIRST Attach the Perimeter Isolation Strip to the wall (see diagram #1) at the bottom of the Perimeter Isolation Strip. It will be trimmed later at the height of the finished floor.
2. Assume the walls you are butting up against are not square. Using a chalk line, create a starting point for an edge of the material to follow.
3. Remove the shrink-wrap from the roll and unroll onto floor. Allow to relax 2 hours. Shaking the material once it is unrolled can help it to relax.
4. Place the Iso-Step® Soundproofing Underlayment material so that it is perpendicular to the subsequent installation direction of the finished flooring (see diagram #3).
5. Trim as necessary to fit surface area to be covered.
6. Align the roll edges with each other. Edges must contact but not overlap.

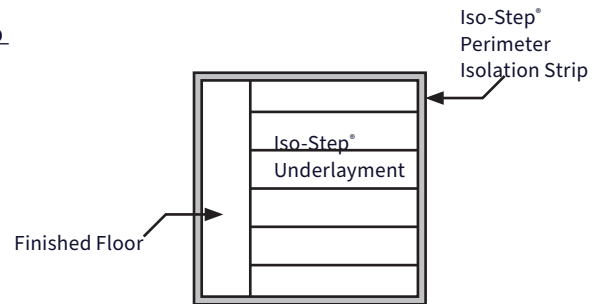

Diagram 3

B. GLUING ISO-STEP® SOUNDPROOFING UNDERLAYMENT

NOTE: When using grouted or fully adhered flooring materials, Iso-Step® Soundproofing Underlayment shall be fully adhered to the substrate with a suitable adhesive. No substitutions are permitted. Iso-Step® Soundproofing Underlayment may be loose laid for floating floors.

1. After Iso-Step® Soundproofing Underlayment is rolled out and allowed to relax, fold material halfway back (half the width of the roll) to expose substrate. Spread adhesive on exposed substrate using proper trowel:
 - a. Less than 4mm Iso-Step® Soundproofing Underlayment – Use a 1/16" x 1/32" x 1/32" U notched trowel
 - b. 4mm and thicker – Use a 1/16" square notched trowel.

NOTE:

- **Acoustical Solutions recommends using Iso-Step® Soundproofing Underlayment Adhesive or Iso-Step® Quick Cure Soundproofing Underlayment Adhesive when installing grouted materials.**
- **Iso-Step® Soundproofing Underlayment Adhesive or Iso-Step® Quick Cure Soundproofing Underlayment Adhesive can be used for ANY thickness Iso-Step® Soundproofing Underlayment.**
- **Temperature and humidity affect adhesive open time; monitor on-site conditions and adjust open time accordingly.**

continues...

Iso-Step® Soundproofing Underlayment

General Information

2. Carefully lay the material into the wet adhesive. DO NOT allow material to “flop” into place, as this will trap air under the material.
3. Fold over second half of first sheet and first half of second sheet.
4. Spread the adhesive. At seams, spread adhesive at 90 degrees to prevent excessive adhesive from oozing up to the surface of the material. Never leave adhesive ridges or puddles, which can telegraph up through the material.
5. Continue the process for each consecutive drop, always folding material back into wet adhesive.
6. Use a 35 to 75 lb roller, within 45 minutes, to roll the floor to ensure proper transfer of adhesive. Overlap each pass of the roller by 50% of the previous pass.
7. Repeat procedure for all sections of Iso-Step® Soundproofing Underlayment until room is finished.

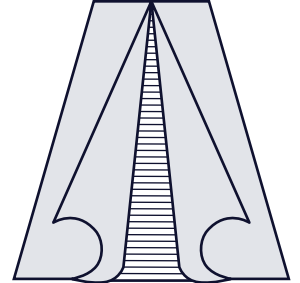

VII. Alternative Installation Methods for Iso-Step® Underlayment

A. GENERAL

1. Follow the flooring manufacturer’s directions for installing the flooring. Use their recommended adhesives, procedures, and equipment.
2. Do not mechanically fasten any material through Iso-Step® Soundproofing Underlayment. Any mechanical connection, such as nails, screws, staples, etc., will transmit noise through to the building structure, compromising the performance of the material.

B. FLOATING FLOORING

NOTE: Gluing down Iso-Step® Soundproofing Underlayment is not required for floating floors.

1. Attach Perimeter Isolation Strip (per above).
2. Dry lay the rolls onto the subfloor with duct or carpet tape to hold seams together.

C. PLYWOOD OR CEMENT BOARD

1. If a flooring manufacturer recommends the installation of a layer of plywood or cement board between the Iso and the finished flooring, glue the recommended board using a suitable adhesive.
2. Apply adhesive to the Iso-Step® Soundproofing Underlayment using the manufacturer’s recommended trowel size.
3. Do not mechanically fasten any material through Iso-Step® Soundproofing Underlayment. Any mechanical connection, such as nails, screws, staples, etc., will transmit noise through to the building structure, compromising the performance of the material.

D. SHEET VINYL OR LUXURY VINYL TILE AND PLANK

1. Sheet vinyl is not an approved installation method over the Iso-Step® Soundproofing Underlayment.
2. For LVT installation, refer to the LVT manufacturer’s instructions.

continues...

Revised: 2025-04-30

Iso-Step® Soundproofing Underlayment

General Information

E. CERAMIC AND PORCELAIN TILE

1. Apply approved thinset mortar directly onto Iso-Step® Soundproofing Underlayment as directed by mortar manufacturer.
2. Follow mortar and tile manufacturers' installation procedures.

F. GLUE DOWN WOOD FLOORING

1. Follow the flooring manufacturer's directions for installing the flooring over Iso-Step® Soundproofing Underlayment. Use their recommended adhesives, procedures, and equipment.
2. Do not mechanically fasten any material through Iso-Step® Soundproofing Underlayment. Any mechanical connection, such as nails, screws, staples, etc., will transmit noise through to the building structure, compromising the performance of the material.

G. NAILED DOWN WOOD FLOORING

1. Follow the flooring manufacturer's directions to install flooring over the Iso-Step® Soundproofing Underlayment. Use their recommended adhesives, procedures, and equipment.
2. Do not mechanically fasten any material through Iso-Step® Soundproofing Underlayment. Any mechanical connection, such as nails, screws, staples, etc., will transmit noise through to the building structure, compromising the performance of the material.

VIII. Baseboard

A. INSTALLATION OF BASEBOARD

1. Only install baseboard after Perimeter Isolation Strip has been trimmed flush to floor height.
2. In order to isolate the floor from the wall and break the vibration transmission path, the baseboard must not touch the finished floor.
3. Seal between baseboard and floor surface with an ASTM C920 approved elastomeric joint sealant.

Revised: 2025-04-30

Iso-Step® Soundproofing Underlayment

General Information

IX. Recommended Materials

NOTE: All materials shall be delivered to the job site in the original containers with all manufacturers' identification and labels intact. Unauthorized modification to any product is not permitted.

A. APPROVED URETHANE ADHESIVES

Please note: The following urethane adhesives are ONLY suitable for Concrete and Portland based patches and self-levelers. They are not suitable for gypsum.

1. Iso-Step® Soundproofing Underlayment Adhesive
2. Iso-Step® Quick Cure Soundproofing Underlayment Adhesive
3. Bostik's Best® by Bostik®
4. Bostik Green Fusion
5. Mapei Ultrabond® ECO 980
6. Chemrex 941 by BASF

B. APPROVED THIN-SET MATERIALS

1. ANSI A118.4 Standard Modified Dry-Set Cement Mortar
2. ANSI A118.15 Improved Modified Dry-Set Cement Mortar

C. APPROVED GROUT MATERIALS

1. ANSI A118.6 Standard Performance Grout
2. ANSI A118.7 High Performance Grout
3. ANSI A118.8 Modified Epoxy Grout

D. APPROVED GYPSUM PRIMERS

1. Mapei – Primer T
2. Ardex – P51
3. Bostik – Universal Primer
4. Specco S-55

E. APPROVED CEMENTITIOUS BACKERBOARD

1. ANSI A118.9 Standard Cementitious Backer Board Unit (CBU)

F. APPROVED ACOUSTICAL SEALANT

1. ASTM C920 Standard Specification for Non-hardening Elastomeric Joint Sealant

Revised: 2025-04-30

Iso-Step® Soundproofing Underlayment

Warranty

Acoustical Solutions offers a limited lifetime warranty on the Iso-Step® brand of Impact Sound Insulation products against defects in material and workmanship, and Iso-Step® shall meet all published specifications and perform effectively. Acoustical Solutions warrants that during the warranty period, Iso-Step® shall not harden, become brittle, chip, crack, tear, or exhibit any signs of excessive deterioration except for normal wear and tear. All other warranties, including implied warranties for a particular purpose, wear due to ultraviolet degradation, and uses and installations that are contrary to Iso-Step® specifications, recommendations or instructions are expressly excluded. The sole remedy against the seller will be the replacement or repair of the defective goods; or, at seller's option, credit may be issued not exceeding the selling price of the defective good. Lifetime means for so long as the job installation remains unchanged by the original owner.

The recommendations for applications and installation contained within this document are based on our extensive experience and current technological practice. Acoustical Solutions' liability and responsibility in the event of damages is limited to the extent defined in our General Terms and Conditions of Business and is not in any way increased by advice given by our sales representatives or applications engineering staff.

Revised: 2025-04-30