

## INSTALLATION GUIDE

# Overly Quick Ship Metal Acoustical Door

The following installation instructions are given as a general guide to avoid common errors. Installer should follow best practices for construction and workmanship. Acoustical Solutions bears no responsibility for installation or contractor selection. Please contact a sales representative if you have questions, concerns or specific project requirements.

Be sure to inspect materials upon delivery. Please note any damage on the delivery ticket and notify Acoustical Solutions immediately. Materials should be stored in original packing in a clean, climate controlled environment free of moisture. Installation should not commence until building is enclosed and under standard occupancy conditions and surfaces are of acceptable condition and properly prepared. Do not install materials of unacceptable quality.

## Installation Instructions For 1-3/4" Acoustical Door Units

### Angle Magnetic Seals And Super "H" Door Bottoms



Revised: 2025-04-30

# Overly Quick Ship Metal Acoustical Door

## General Information

The proper performance of most manufactured building products depends not only on how they are made, but how they are installed. This is particularly true of **Acoustical Door** units. Anyone acquainted with building construction knows that the proper installation of the frames and doors is an operation that requires great skill and care. Even the best designed and most carefully made frames and doors, if improperly installed, will not function or perform to their intended maximum effectiveness. Additionally, **Acoustical Door** openings require careful adjustment of the perimeter sealing systems in order to obtain the desired level of acoustical performance.

Overly Door Company is concerned that our product is properly handled and protected after delivery, and that the necessary care and skills are exercised in the setting of our frames and hanging of our doors. It is important to all concerned, therefore, that attention be given to the essential requirements of good practice in field installation work. Use of these installation instructions in combination with the approved shop drawings and your attention to good workmanship will provide the proper installation and operation of Overly Acoustical Doors and Frames.

## Delivery and Receiving of Materials

**Acoustical Doors and Frames** are fabricated in accordance with shop drawings that have been approved by the architect or design engineer. Preparations for hardware and/or other items to be supplied by others are provided in accordance with the information provided to Overly by the hardware supplier or by those other suppliers or trades with whom the work is being coordinated.

Should any material be damaged in shipment, claims should immediately be filed by the receiving party, who should notify the delivering carrier's regional office by telephone or in writing, requesting inspection of the damaged material. If desired, Overly Door will cooperate by furnishing copies of shipping papers or other pertinent information to help expedite the claim. Accepted materials become the customer's responsibility to protect and store accordingly.

If a claim is to be made for any error or deficiency in the materials supplied, it is imperative that Overly be notified in writing before initiating any corrective action in the field. Overly Door has its own field representatives who are qualified not only to do expert repair work but to determine whether the fault lies with the manufacturer or with some other party.

## On-Site Storage

Improper storage of **Acoustical Doors and Frames** at the construction site often results in the deterioration of the shop primer coat of paint. Such deterioration is a continuing source of aggravation to all concerned.

Particular attention must be given to steel products which are to be stored having only one coat of shop primer if corrosion is to be avoided. Because the protective shop primer must be porous to properly receive and hold top coats, water or moisture in contact with prime coated steel will seep through to the steel by capillary action. An electrolytic action then follows, resulting in corrosion and causing the paint to lose adhesion. The presence of oxygen at the water-air interface behind the loosened paint film accelerates corrosive action and further prime coat deterioration.

Manufacturers of metal acoustical doors and frames have found that one week of exposure to water because of improper storage is equivalent to at least a year of outdoor exposure to the elements.

It is imperative that those parties who are responsible for the storage of primed metal work at the job-site be carefully instructed as to proper storage procedures. All ferrous metal products should be stored where they are least likely to be exposed to contact with water.

Revised: 2025-04-30

# Overly Quick Ship Metal Acoustical Door

The following steps should always be observed when storing **Acoustical Doors and Frames** at the job-site:

1. Store all materials in a dry area under cover.
2. Place all material on planking or blocking at least 4" off of the ground, 2" off of slab or paved area.
3. Do not stack material flat. Store with frames in an upright position.
4. Provide, by means of wood or styrofoam strips, a space of at least ¼" between all units, to allow air to circulate between them.
5. Do not permit cardboard or paper to become wet and come in contact with the frames. If this should occur, remove them immediately.

## Uncrating Instructions

Depending on the size of your particular order and the manner in which items required for the door and frame installation were ordered, the crate which you have received may contain one, two or several acoustical units. The quantity and type of items provided by Overly can be found on the packing list located on the outside of the crate. Many times, other items such as glass, hardware, etc., that are required for a complete opening, is provided by an outside source and should be coordinated with the Overly door and framing system. As you uncrate, review the packing list and locate the following items for a complete installation:

1. **Frame** — identification information on the frame can be found on a small white tag located on one of the frame hinge reinforcements. This information includes Overly order number, unit mark number and swing. If a UL Fire Label is provided, it can be found attached to the hinge jamb rabbet.
2. **Door(s)** — depending on if you have a single or pair of doors, a similar white tag is utilized to identify the door and includes the same information as the frame. If a pair of doors is provided, the mark number will contain an "A" after it for the active leaf, and an "N" after it for the inactive leaf.
3. **Frame Gasketing System** — The Overly magnetic seal gaskets retainers, covers and associated fasteners are packaged together and labeled with the mark number information. If pairs of doors are supplied, a surface mounted astragal for the inactive leaf with associated fasteners are packaged together and labeled with mark number information.
4. **Super "H" Compression Type Door Bottom** — this particular model door requires the use of Overly's Super "H" compression type door bottom assembly that is shipped loose in a styrofoam shipping package with associated fasteners and labeled with the mark number information.
5. **Cam-Lift Hinges** — this particular unit requires the use of Overly cam-lift hinges. These hinges are supplied in a small white box labeled with the words cam-lift hinges and the opening mark number and swing.
6. **Anchors** — Frame anchors have been provided. Check packing list and shop drawings as to type required and supplied.
7. **Pink Noise Source** — The CD is located inside the installation instruction envelope. Place in a safe place for use later during gasket installation and adjustment.
8. **Mounting Brackets** — If stop mounted closers or latching hardware are to be used, "Z" or "L" shaped brackets are supplied with associated fasteners and labeled with mark number information. Check packing list to see if any such brackets have been supplied.

Miscellaneous items such as thresholds, locksets, flushbolt, glass, etc., may or may not have been provided by Overly. Be sure to check packing list and shop drawings for further details.

Revised: 2025-04-30

# Overly Quick Ship Metal Acoustical Door

## Frame Installation Procedure

**Note:** Prior to installation of the frame, it is recommended that the installer obtain copies of architect's plans and approved hardware schedule prior to beginning installation.

The frame assembly provided consists of a 4-sided welded unit that was factory inspected prior to shipment to assure that they are square and that no jamb twists have occurred during their fabrication. To minimize misalignment or other damage during shipment, the frames are packed and loaded onto the carrier by personnel experienced in frame packaging. However, in spite of these precautions, the frames can and sometimes do arrive at the jobsite with minor deviations. Should this occur, most out-of-square and misalignment problems can be readily corrected during installation.

Frame anchorage systems are custom designed to accommodate individual project opening requirements to suit specified wall conditions. Therefore, it is necessary to refer to the approved shop drawings for each individual frame for the method of anchorage. The four general types of anchorage covered by these instructions include:

1. Built-in masonry
2. Built-in drywall with wood or channel studs
3. Bolt-in masonry
4. Bolt-in drywall with wood or channel studs

At this time, review the shop drawings for the openings and proceed to the type of installation required. Regardless of the anchorage system required, the installation guidelines must be adhered to. At anytime during the installation of the product, if questions arise, **call Overly Door at 1-724-834-7300.**

## 1. Built-in Masonry Partition

1. Remove temporary steel spreader from bottom of frame.
2. Use some type of triangular support and bracing device that will securely hold the frame in the exact location and alignment required for proper installation. Usually such bracing is made of wood. However, metal "jacks" or supporters designed specifically for this purpose are commercially available, and their use is recommended.
3. Cut  $\frac{3}{4}$ " thick temporary wood spreaders to accurate jamb dimensions and locate at  $\frac{1}{3}$  points of the frame and at the sill.
4. Check that the frame is square and aligned by measuring the diagonal dimensions and "cross string" the frame to insure that the jambs are properly set. (See Figure 1).
5. While protecting the frame from accidental abuse, build walls to the frame utilizing the strap anchors attached to the frame, making sure that proper frame alignment is maintained.

**Note:** As the walls are being built, the frame must be grouted full to ensure maximum acoustical performance. Extreme caution must be exercised while performing this operation to make sure the head does not sag nor the jambs or sill be allowed to bow.

6. After the frame is permanently built into the wall, with all strap anchors installed and cement and/or grout set, remove the wood spreaders.
7. Caulk frame continuously around perimeter of frame on both sides at frame/wall interface.

*continues...*

Revised: 2025-04-30

# Overly Quick Ship Metal Acoustical Door

**Note:** A threshold may be required for the opening. This threshold may or may not have been provided by Overly. Refer to shop drawings as to if one is required, and who may have supplied it. Thresholds must have smooth, flush top surfaces. No textured or fluted thresholds permitted.

8. If one is required, install at this time between the frame jambs, as shown on the drawings. The threshold should be set in dense mastic or acoustical sealant.

Now Proceed to “**Installation of Door(s)**” section.

## 2. Built-in Drywall Partition

1. Remove temporary steel spreader from bottom of frame.
2. Use some type of triangular support and bracing device that will securely hold the frame in the exact location and alignment required for proper installation. Usually such bracing is made of wood. However, metal “jacks” or supporters designed specifically for this purpose are commercially available, and their use is recommended.

**Note:** At this point, the frame must be packed full with 6 to 12 PCF density mineral wool in the form of blanket or board type, to ensure the maximum acoustical performance of the opening.

3. Cut  $\frac{3}{4}$ " thick temporary wood spreaders to accurate jamb dimensions and locate at  $\frac{1}{3}$  points of the frame and at the sill.
4. Check that the frame is square and aligned by measuring the diagonal dimensions and “cross string” the frame to insure that the jambs are properly set. (See Figure 1).
5. While protecting the frame from accidental abuse, build walls to the frame utilizing the “Z” anchors attached to the frame, making sure that proper frame alignment is maintained.
6. After the frame is permanently built into the wall, with all anchors installed, remove the wood spreaders.
7. Caulk frame continuously around perimeter of frame on both sides at frame/wall interface.

**Note:** A threshold may be required for the opening. This threshold may or may not have been provided by Overly. Refer to shop drawings as to if one is required, and who may have supplied it. Thresholds must have smooth, flush top surfaces. No textured or fluted thresholds permitted.

8. If one is required, install at this time between the frame jambs, as shown on the drawings. The threshold should be set in dense mastic or acoustical sealant.

Now Proceed to “**Installation of Door(s)**” section.

## 3. Bolt-in Masonry Partition

**Note:** Masonry openings that are to receive pre-assembled welded frames must be accurately constructed. They should be  $\frac{1}{2}$ " wider than the overall frame width dimension and  $\frac{1}{4}$ " higher than the overall frame height, to provide a clearance on all sides of  $\frac{1}{4}$ " to allow for shimming during installation. Overly recommends the use of metal shims when shimming is required due to the weights of acoustical doors.

**Note:** At this point, check the approved shop drawings or architects plans to see if the frame is to be grouted full or packed with

Revised: 2025-04-30

# Overly Quick Ship Metal Acoustical Door

mineral wool. If the frame is to be grouted full, proceed to Step A. If the frame must be packed full, pack all frame cavities full at this time using 6 to 12 PCF density mineral wool in the form of blanket or board type, to ensure the maximum acoustical performance of the opening.

1. Remove temporary steel spreader from bottom of frame.
2. Insert frame into prepared opening and shim frame as required to maintain the tolerances shown in Figure 1 and securely anchor the frame to the wall using the anchor bolts of type and dimensions specified on the approved shop drawings. If the frame is UL labeled, UL approved anchors were provided with the shipment for installation, otherwise, anchors may not have been provided.
3. Check that the frame is square and aligned by measuring the diagonal dimensions and “cross string” the frame to insure that the jambs are properly set. (See Figure 1).

**Note:** If the frame is to be grouted in place, grout at this time with Gold Bond Gypsolite Plaster by National Gypsum or Structo-Lite by US Gypsum or equal. Extreme caution must be exercised while performing this operation to make sure the head does not sag nor the jambs bow. Support frame head and jambs with adequate bracing, removing only after grout has had sufficient time to cure.

4. Caulk frame continuously around perimeter of frame on both sides at frame/wall interface.

**Note:** A threshold may be required for the opening. This threshold may or may not have been provided by Overly. Refer to shop drawings as to if one is required, and who may have supplied it. Thresholds must have smooth, flush top surfaces. No textured or fluted thresholds permitted.

5. If one is required, install at this time between the frame jambs, as shown on the drawings. The threshold should be set in dense mastic or acoustical sealant.

Now Proceed to “**Installation of Door(s)**” section.

## 4. Bolt-in Drywall Partition

**Note:** Drywall openings that are to receive pre-assembled welded frames must be accurately constructed. They should be ½" wider than the overall frame width dimension and ¼" higher than the overall frame height above the finished floor, to provide a clearance on all sides of ¼" to allow for shimming during installation. Overly recommends the use of metal shims when shimming is required due to the weights of acoustical doors.

**Note:** At this point the frame must be packed full, pack all frame cavities at this time using 6 to 12 PCF density mineral wool in the form of blanket or board type, to ensure the maximum acoustical performance of the opening.

1. Remove temporary steel spreader from bottom of frame.
2. Insert frame into prepared opening and shim frame as required to maintain the tolerances shown in Figure 1 and securely anchor the frame to the wall using the anchor bolts of type and dimensions specified on the approved shop drawings. If the frame is UL labeled, Overly’s standard UL approved anchors were provided with the shipment for installation, otherwise, anchors may or may not have been provided.

*continues...*

Revised: 2025-04-30

# Overly Quick Ship Metal Acoustical Door

3. Check that the frame is square and aligned by measuring the diagonal dimensions and “cross string” the frame to insure that the jambs are properly set. (See Figure 1).

4. Caulk frame continuously around perimeter of frame on both sides at frame/wall interface.

**Note:** A threshold may be required for the opening. This threshold may or may not have been provided by Overly. Refer to shop drawings as to if one is required, and who may have supplied it. Thresholds must have smooth, flush top surfaces. No textured or fluted thresholds permitted.

5. If one is required, install at this time between the frame jambs, as shown on the drawings. The threshold should be set in dense mastic or acoustical sealant.

Now Proceed to “**Installation of Door(s)**” section.

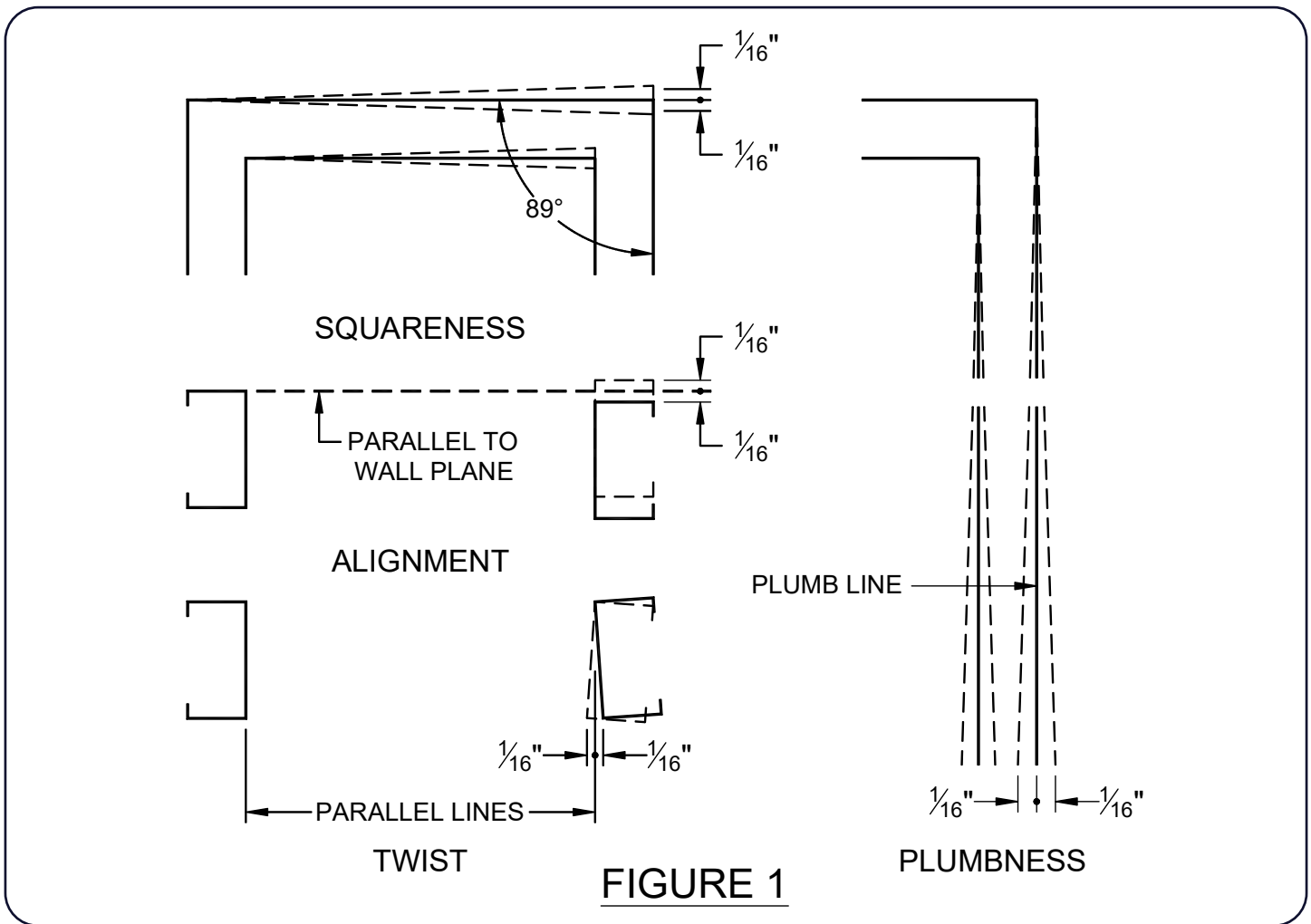

Revised: 2025-04-30

# Overly Quick Ship Metal Acoustical Door

## Installation of Door(s)

**Note:** It is the responsibility of the installer to hang all doors and install all hardware. Holes for the mounting of template hardware are drilled and tapped at the factory. This is not true, however, of preparations for surface mounted items. Adequate reinforcements have been provided for the drilling and tapping of holes for mounting such items. This task is the responsibility of the installer.

**Caution:** Avoid getting dirt or construction debris around the opening. Keep the sill area clean. This cleanliness will avoid unnecessary damage to the sealing system and ensure ease of later adjustment.

This model acoustical door utilizes Overly magnetic frame seals and Overly Super "H" door bottom. The following sections will describe how to hang the door(s), apply and adjust the perimeter sealing system.

1. Locate cam-lift hinges. The cam-lift hinge is a two part hinge consisting of a frame portion and a door portion. Separate the two portions and mount the leaf with the hinge pin to the frame, and the other leaf to the door with the #12-24 x 5/8" long FH screws provided.

Raise the door to the vertical position and drop the door onto the hinge pins.

2. If opening is pair of doors, install second door leaf at this time.

**Caution: Acoustical doors are heavier than conventional hollow metal doors. Have adequate assistance to lift door in position.**

3. If opening is pair of doors, install second door leaf at this time.

**Note:** If inactive leaf requires flush-bolts, install prior to hanging.

**Note:** Overly utilizes a variety of lock edge constructions to achieve varied levels of acoustical performance. These types include a welded seamless edge and an isolated edge which contains a black rubber strip. Determine which type of lock edge you have and follow the instructions below.

**Seamless Lock Edge:** Top flush-bolt may be installed in the normal supplied condition. Bottom flush-bolt rod must be modified by bending to accommodate the presence of the door bottom. See Figure 2 for dimensional requirements for bending rod.

**Isolated Lock Edge:** Before either flush-bolt can be installed, the flush-bolt backsets must be modified. Overly has supplied a "Flush-bolt Extension Kit" for each flush-bolt required. Located these kits and follow the instructions enclosed with them. Once the kits are installed to each flush-bolt, the top one may be installed. Bottom flush-bolt rod must be bent to accommodate the presence of the door bottom. See Figure 2 for bending requirements.

4. Install locksets in door. If the opening is a pair, install strike and flushbolts in inactive leaf.

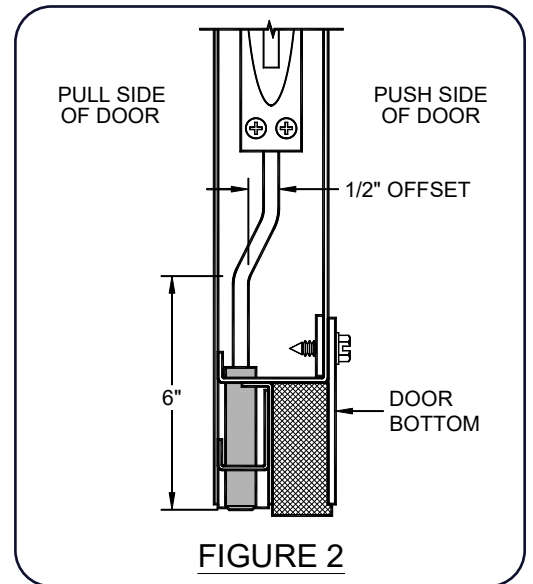
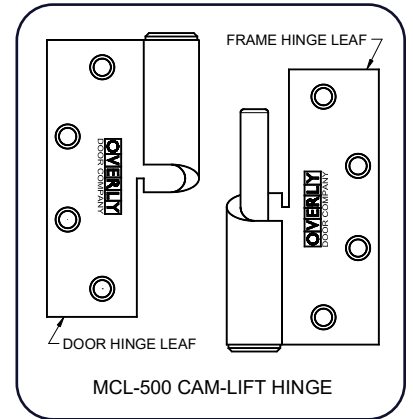

# Overly Quick Ship Metal Acoustical Door

## Door(s) Clearance Adjustment Procedure

Before proceeding with installation of retainers and sealing system, it is essential that uniform clearances between door(s) and frame are maintained. The door(s) and frame have been sized to provide the following clearances:

**For single doors:** 1/8" between Door and Frame Head  
 1/8" between Door and Frame at Hinge Jamb  
 1/8" between Door and Frame at Strike Jamb

**For pairs of doors:** 1/8" between Doors and Frame Head  
 1/8" between Doors and Frame at Jambs  
 1/8" between Doors at meeting stile

Adjustments can be made by following the steps outlined below:

**Note:** Overly recommends the use of metal shims when shimming is required, due to weights of acoustical doors.

To move the door toward the hinge jamb, see Figure 3 and follow these steps:

1. If shim **S1** is used, the door will move towards the hinge jamb of the frame. If shim **S2** is used, both the door and the hinge barrel will move towards the frame.
2. If both shims **S1** and **S2** are used, the door will move further towards the hinge jamb of the frame than by using either **S1** or **S2** alone, and the hinge barrel will be moved to the same position as by using shim **S2** alone.

To move the door away from the hinge jamb, see Figure 4 and follow these steps:

1. If shim **S3** is used, the door will move towards the strike jamb of the frame (or the center of the opening for pairs). If shim **S4** is used, both the door and the hinge barrel will move towards the strike jamb of the frame (or the center of the opening for pairs).
2. If both shims **S3** and **S4** are used, the door will move further towards the strike jamb of the frame (or the center of the opening for pairs). than by using either **S3** or **S4** alone, and the hinge barrel will be moved to the same position as by using shim **S4** alone.

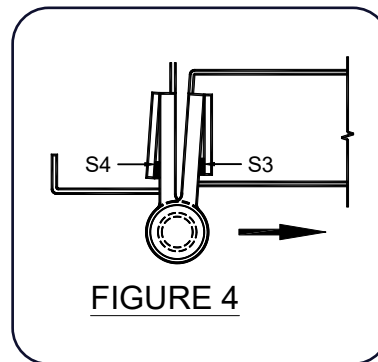
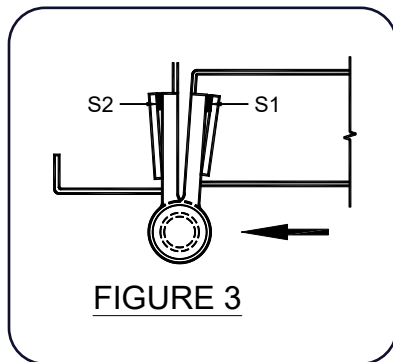

Revised: 2025-04-30

# Overly Quick Ship Metal Acoustical Door

## Retainer and Gasket Installation

**Note:** Prior to installing retainer assemblies, retainers, frames, and doors should be finished painted. The retainers have been supplied with double sided tape and temporary rubber spacers. These spacers will be used to properly position the retainers during installation. Do not damage double sided tape or remove spacers during painting. It is imperative that the paint applied dries completely and forms a smooth, dry, hard surface. At no time should paint be applied to gaskets.

1. Swing door(s) to full open position. Locate the head and jamb retainers, the  $\frac{5}{8}$ " x 1" sponge neoprene and **Fastener Package A**. Install the  $\frac{5}{8}$ " x 1" sponge neoprene in the retainer as shown in Figure 5 below. Trim off any excess neoprene so that there is only  $\frac{1}{8}$ " extended beyond the metal ends of each retainer. Install head retainer with supplied screws. Leave the screws loose enough so the retainers can be moved by pushing with your fingers. Repeat for each side jamb.
2. Close and latch door(s). If no latch is present, close door and maintain  $\frac{1}{8}$ " inset from trim of frame to pull side face of door. With door in this position, slide bumpers on strike jamb retainer against the push side of door and tighten the retainer mounting screws. Repeat this process at hinge jamb and head. ( Note: If bumpers are missing, the gap between the retainers and the push side of door should be 0.4" (approximately  $1\frac{3}{32}$ ").

### **Important: Read before installation! Failure to do so may void guarantee or result.**

1. **Application Temperature:** If frames are **too cold** (below 50°F) or **too hot** (above 100°) adhesion may be impaired. Attempt to elevate ambient temperature. Do **NOT** heat gaskets.
2. **When to Install:** Installation of Overly magnetic gaskets should take place after construction is completed, flooring installed and final cleanup complete.
3. **Paint must be fully cured:** Paint must be thoroughly dry when gaskets are pressed on.
4. **Application Tips and Warnings:**
  - a. **Use very firm, perpendicular, pressure when applying.** Extra pressure required due to product weight and absence of re-compression.
  - b. **Use wallpaper seam roller to reinforce adhesion after applying.** Caution: Do not stretch material when using reinforcing roller. Run roller upon and down a minimum of 3-4 times over entire length of seal.
  - c. **Double check adhesion** after 2-3 hours before leaving job overnight.
  - d. **If gasket separates from frame press again with firm pressure in place.** Note: If adhesive strip is exposed, airborne dust may impede adhesion. Replacement may be necessary at this stage.
  - e. **Headers must be installed with equal pressure at jambs.** Sometimes too little pressure is applied at header due to awkward overhead application.
5. **Note: Adhesion takes delayed set.** Immediate removal and resetting can be done if error occurs in initial replacement. Do NOT reset after one hour. Full set is reached in 24 hours.
3. Locate the carton that has the sound seals for the opening. This carton should have three pieces of magnetic seals, alcohol wipes, and "Magnetic Seal Installation Instructions" (see pages 16–18) Follow these installation instructions for the installation of the magnetic seals.
4. After installing magnetic seals per instructions, slowly close door and check for interference between seals and door. Seal should jump out to meet door at hinge edge and slide slightly toward jamb. If door pushes the side of the magnetic seal at

Revised: 2025-04-30

# Overly Quick Ship Metal Acoustical Door

hinge jamb, stop and move hinge retainer back before closing door completely. Readjust the seal out until the magnet pops out to meet the door. Tighten a couple of the retainer fasteners to hold retainer temporarily. Operate the door a couple of times, making the same observation as at the beginning of this process. If seal is not being pushed to the side tighten all fasteners and reinspect for proper operation.

5. The strike jamb may now be adjusted outward until the door latch operates properly and the door has minimal movement at the latch. Tighten the strike jamb fasteners.
6. Head retainer can now be adjusted to bring the magnet flush to both the hinge jamb magnet and the strike jamb magnet at both ends. Fasteners for the head retainer may now be tightened. Recheck seal operation at all sides while operating the door several times.

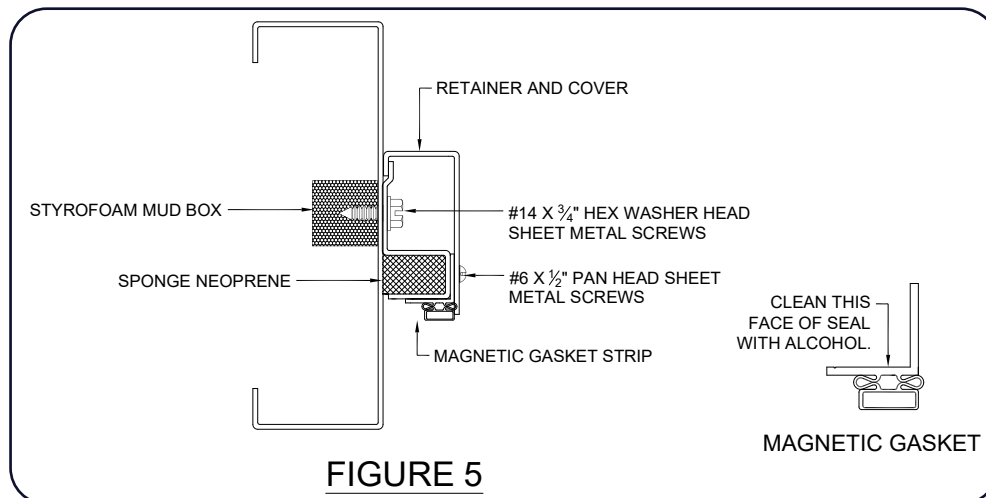

Revised: 2025-04-30

# Overly Quick Ship Metal Acoustical Door

- Open the door(s) and install the Super "H" door bottom(s) by matching up the  $\frac{1}{4}$ " x  $\frac{3}{4}$ " obround slots of the door bottom with the pre-punched holes located on the narrow side skin of the door leaf and securing with the #14 x  $\frac{3}{4}$ " hex washer head screws found in **Fastener Package B**. Each door bottom has been marked with the opening number prior to shipment. Be sure to push the door bottom as far up as possible before tightening the screws. Trim off door bottom ends to match the door width. See Figure 6.

**Note:** If pair of doors is required, locate Astragal and **Fastener Package D**. With the door in the open position, install astragal to the inactive leaf in the pre-drilled holes on the narrow side of the door. Close the door slowly and cut the astragal rubber at the finished floor and at the head retainer. Close and secure the inactive leaf, then close and latch the active leaf. Visually check to see if the astragal rubber contacts the active leaf. At areas where the gasket does not contact the door face, shimming the gasket may be necessary. The gasket is affixed to one side of the steel retainer with a  $\frac{3}{4}$ " wide strip of double faced tape as shown in Figure 7. The side closest to the active leaf is left free to allow it to be lifted and shims placed behind. Shims should only be placed in sections where the gasket does not contact active door face.

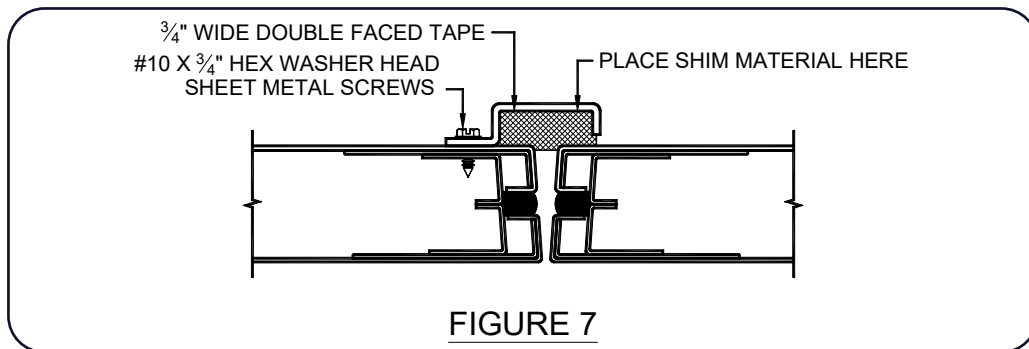
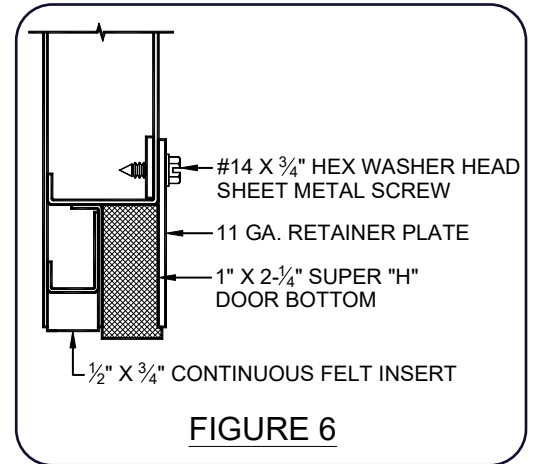

# Overly Quick Ship Metal Acoustical Door

## Final Gasket Adjustment Procedure

**Required Equipment:** A CD player, a mechanic's stethoscope, hammer, and hardwood block. A doctor's stethoscope may be converted to a mechanics type by replacing the listening end with an 18" long piece of 1/8" diameter copper tubing.

1. Using the pink noise CD that was provided, place it into the player and set it to a high volume level that is uncomfortable for normal hearing. Locate the player approximately 3 feet from the door on the hinge side.
2. Close and latch the door.
3. Apply the "ear" or probe of the stethoscope to the line between the magnetic gasket and where it contacts the door. Beginning on the lower hinge side, make a slow first pass around the perimeter of the seal line to detect major leakage points, marking these high points as you go.
4. Beginning at the hinge side, adjust the gaskets by tapping the retainer to drive it closer to the door at the areas identified in step C. Use the stethoscope after each adjustment to verify the changes in sound attenuation.

**Note:** It is important to note that the purpose of the magnetic seal is to reduce and minimize the sound attenuation of the unit. The ideal setting for the seals is if the attenuation is of a uniform distribution.

5. When noise level is uniform along the hinge side gasket, work across the head gasket retainer from the hinge to latch jambs.
6. Repeat the same procedure along the latch side gasket retainer.
7. Repeat the same procedure along the door bottom by lightly driving the door bottom cover plate towards the top of the sill/threshold.

**Caution:** All types of door bottoms have inherent leaks at the corners; therefore, when fine tuning with the stethoscope an increase in sound levels to be expected. Do not attempt to put excessive pressure on the door bottom gasket to eliminate this condition. If excessive force is tried, the condition will remain the same, but the door bottom will be damaged.

8. Fine tune the installation by once again running the stethoscope around the seal line to ensure a uniform level of sound attenuation has been achieved. If acoustical leaks are discovered, drive the gasket retainer toward the door with light hammer taps.

**Note:** If leaks persist at the top corners, apply a small amount of RTV silicone sealant to the butting edges of the gasket retainers and allow to cure. This should eliminate the condition. Some leakage is normal at the corners, especially the bottom ones.

9. Firmly torque down the gasket retainer screws. Locate retainer covers and **Fastener Package C** containing the #6 x 1/2" long round head sheet metal screws. The steel covers are pre-punched with mounting holes. Use these holes as a template for drilling the retainers for the sheet metal screws. Install covers as shown in Figure 5. If a threshold is installed, covers may need to be cut down and/or notched to clear height and profile of threshold.

Note: Do not caulk around the perimeter of any retainer covers (Including jambs and head) where the retainer meets the frame on the opening. Covers are meant to be removable at all times.

Revised: 2025-04-30

# Overly Quick Ship Metal Acoustical Door

## “Z” or “L” Bracket Instructions

At no time should any hardware item be mounted to the retainer stop system. For situations that require the need for stop mounted hardware, Overly provides a “Z” or “L” shaped bracket to accommodate this. The “L” bracket is supplied on frames with a jamb depth of less than 6", while the “Z” bracket is supplied on frames with a jamb depth of 6" or greater. Figure 8 shows the height of the brackets. Use this dimension in combination with the device manufacturers instructions and mount hardware accordingly.

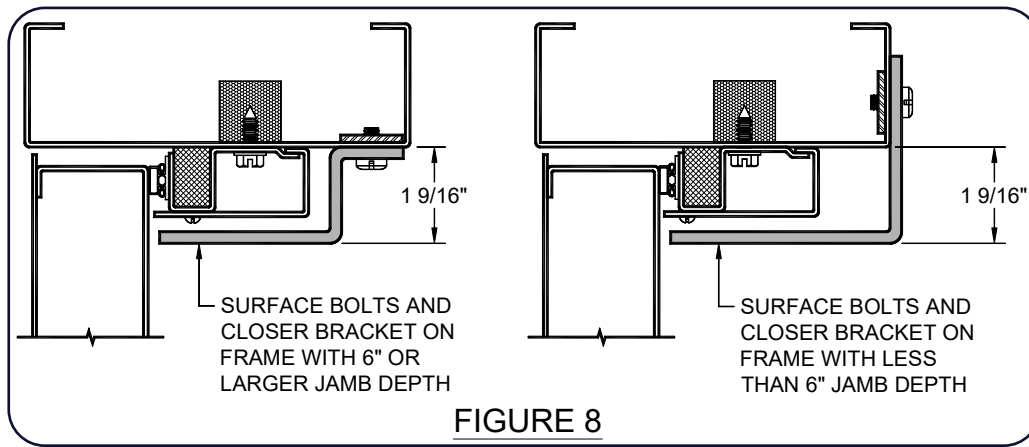

Revised: 2025-04-30

# Overly Quick Ship Metal Acoustical Door

## Magnetic Seal Installation Instructions

Ensure that all painting is complete and paint is fully cured.

1. Retainers should be installed with sealing rubber completely sealed around 3 sides of the frame, as seen in the picture to the right.
2. Retainer should be adjusted with temporary spacers against door in closed and latched position (See picture to the right.) If spacers are not present, the space between retainer and door face should be approximately  $1\frac{3}{32}$ ".
3. Starting with the head retainer, find the seal that measures the same as the Jamb Opening Width.
4. Carefully clean the area on the back of the seal that will contact the double faced tape located on the retainer. This should be done using the alcohol wipes provided. Do not use mineral spirits or other petroleum cleaning products.
5. Remove the protective paper cover from the double faced tape as well as any temporary bumpers from the retainer.



Revised: 2025-04-30

## INSTALLATION GUIDE

# Overly Quick Ship Metal Acoustical Door

- Starting at one end apply seal against the jamb forcing the leg without the magnet between the end of the jamb retainer and the head retainer. (This leg will push in above the rubber seal.) Make sure that both faces of the seal are lying against the retainer.

**Note:** This process can be aided by flexing the corner of the seal slightly. See front and rear view pictures below.



- After seal has been completely installed, roll seal tightly with wall paper roller on similar tool. Repeat this rolling process over entire length 3 or 4 times.

**Note:** If at any time the magnetic strip comes out of the vinyl extrusion, it must be reinserted prior to installation of the gasket on the retainer. Re-insert the smooth side of the magnet so that it is facing the door contact side of the gasket.

- Before installing jamb seals, check length as the retainer may have been cut to accommodate a threshold. Seal length should match measurement from bottom of head seal to bottom of retainer. If seal is long, trim length at top as magnet will be loose and will slide out the bottom. (Note: Seals will be handed and you will need to cut accordingly.)
- Clean jamb seal with the alcohol wipes provided.
- Remove the protective paper as per step #5 on page 15.
- Starting at the top, apply seal to retainer. Make sure that both faces are lying against the retainer. The magnet area of jamb seal must be butted against bottom of head magnet area.
- After seal has been completely installed, please refer to step #7 on this page.
- Repeat the process at the opposite jamb.
- Return to page 10 to complete installation of the unit.



Revised: 2025-04-30