

Resilient Sound Isolation Clip (RSIC-1)



Description

Resilient Sound Isolation Clips (RSIC-1) create a high STC (Sound Transmission Classification) rating for your wall or ceiling assembly, and offer an economical method to “float” your walls or ceilings. These isolation clips are used for vibration control of structure-borne noise, and help build assemblies that will more effectively block airborne noise transmission. For higher rated sound blocking applications with improved STC ratings, use the isolation clips in combination with AudioSeat® Mass Loaded Vinyl (MLV) Soundproofing Barrier and Green Glue Damping Compound.

Resilient Isolation Clips are made with a natural blend neoprene grommet pad and threaded shaft, which is attached to a center bushing made of electroplated zinc mild steel. The center bushing is approximately 20 mm long, with a 10 mm shaft section and 21.5 mm end clip. The natural neoprene isolator is 1½" x ½".

The RSIC-1 is designed for use with any wood, steel, or concrete application where noise control is required. This includes wood framed, steel framed, CMU, or concrete wall or ceiling systems. The RSIC-1 assembly decouples gypsum board from the underlying structure to provide enhanced acoustical performance. With an acoustical design load rating of 36 lbs per isolator, the clip can support up to two layers of ½" gypsum board when spaced no more than 24" x 48" O.C. The RSIC-1 clip fastens directly to the framing or structure to prevent sound and vibrations from entering the adjacent space. This improves the STC and IIC ratings of construction assemblies.

Technical Characteristics

Size (nominal):	3" x 1-1/4" x 1-7/16"
Projection:	1 5/8" from supporting structure, when 7/8" drywall furring channels are used
Construction:	Natural and manufactured rubber molded to isolate ferrule (zinc-electroplated steel) from 16 gauge galvanized or aluminum-zinc coated clip. Minimum of 12 micro-vibration controlling pedestals at point of contact with framing member
Intended Use:	Wall & ceiling construction assemblies to prevent sound & vibration transmission to improve STC and IIC ratings
Dead or Shear Load:	Maximum design load of 36 pounds per each resilient sound isolation clip.
Total Deflection:	3 mm
Double Deflection:	Yes (1.5mm)

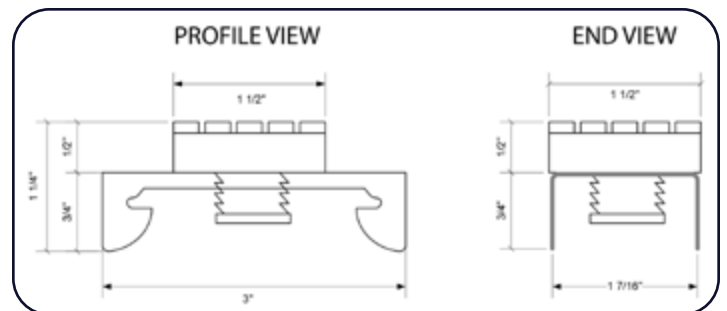

Revised: 2025-04-30